



Operating Manual Ultrasonic proximity switch with one switched output and IO-Link interface

pico+15/TF/F
pico+25/TF/F
pico+35/TF/F
pico+100/TF/F



Product description

The pico+ sensor offers a non-contact measurement of the distance to an object which must be positioned within the sensor's detection zone. The switched output is set conditional upon the adjusted detect distance. The ultrasonic transducer surface of the pico+ sensors is laminated with a PTFE film (Teflon film). The transducer itself is sealed against the housing by a joint ring. This composition permits measurement in up to 0.5 bar over pressure. Via the Teach-in procedure, the detect distance and operating mode can be adjusted. Two LEDs indicate operation and the state of the switched output.

IO-Link

The pico+ sensors are IO-Link-capable in accordance with IO-Link specification V1.0.

Safety instructions

- Read the operating instructions prior to start-up.
- Connection, installation and adjustments may only be carried out by qualified staff.
- No safety component in accordance with the EU Machine Directive.

Use for intended purpose only

pico+ ultrasonic sensors are used for non-contact detection of objects.

Installation

- Mount the sensor at the place of fitting.

		colour
1	+U _B	brown
3	-U _B	blue
4	F	black
2	-	white
5	Com	grey

Fig. 1: Pin assignment with view onto sensor plug and colour coding of the microsonic connection cables

- For the pico+100/TF/F we recommend not to use for mounting the first 5 mm of the M22 thread on the side of the transducer.
- Connect a connection cable to the M12 device plug.

Start-up

- Connect the power supply.
- Carry out sensor adjustment in accordance with the diagram.

Factory setting

- Detect point operation
- Switched output on NOC
- Detect distance at operating range
- Multi-function input »Com« set to »Teach-in«
- Filter at F01
- Filter strength at P00

Operating modes

Three operating modes are available for the switched output:

- Operation with one detect point

The switched output is set when the object falls below the set detect point.

Window mode

The switched output is set when the object is within the set window.

- Two-way reflective barrier

The switched output is set when the object is between sensor and fixed reflector.

Synchronisation

If under multiple sensor operation the assembly distance falls below the values shown in Fig. 2, the internal synchronisation should be used. For this purpose set the switched outputs of all sensors in accordance with the diagram »Sensor adjustment with the Teach-in procedure«. Then change the multi-function output »Com« to »synchronisation« (see »Further settings«). Finally interconnect each pin 5 of the sensors to be synchronised.

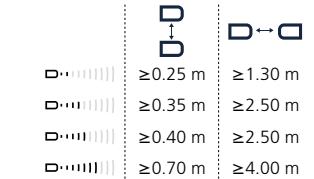

Fig. 2: Assembly distances

Maintenance

microsonic sensors are maintenance-free. In case of excess caked-on dirt we recommend cleaning the white sensor surface

Notes

- The sensors of the pico+ family have a blind zone, within which a distance measurement is not possible.
- The pico+ sensors are equipped with an internal temperature compensation. Due to the sensors self heating, the temperature compensation reaches its optimum working-point after approx. 120 seconds of operation.
- In the normal operating mode, an illuminated yellow LED signals that the switched output is switched through.
- The pico+ sensors have a push-pull switched output.
- In the »Two-way reflective barrier« operating mode, the object has to

Contact

Sensor Partners BV

James Wattlaan 15
5151 DP Drunen
The Netherlands
+31 (0)416 - 37 82 39
info@sensorpartners.com
sensorpartners.com

Sensor Partners BVBA

Z.1 Researchpark 310
B-1731, Zellik
Belgium
+32 (0)2 - 464 96 90
info@sensorpartners.com
sensorpartners.com

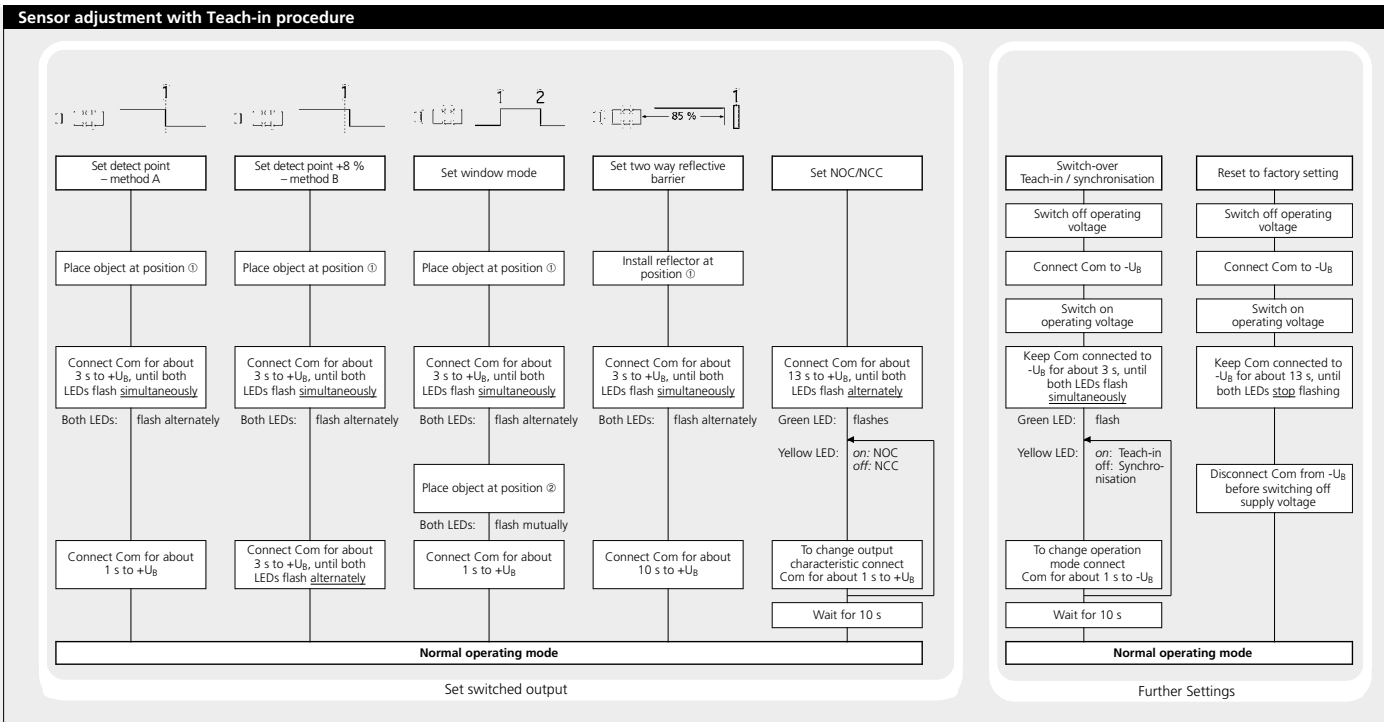

Technical data

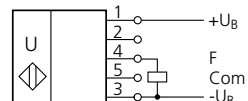

Push-Pull output in pnp circuit

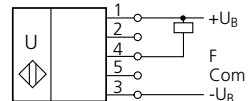

Push-Pull output in npn circuit

blind zone
operating range
maximum range
angle of beam spread
transducer frequency
resolution
reproducibility

detection zones

The dark grey areas represent the zone where it is easy to recognise the normal reflector (round bar). This indicates the typical operating range of the sensors. The light grey areas represent the zone where a very large reflector – for instance a plate – can still be recognized. The requirement here is for an optimum alignment to the sensor. It is not possible to evaluate ultrasonic reflections outside this area.

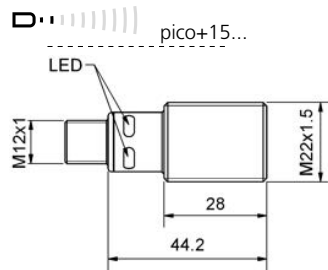

20 mm
 150 mm
 250 mm
 see detection zone
 380 kHz
 0.069 mm
 ± 0.15 %

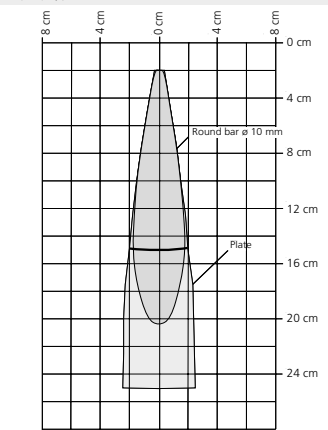

accuracy ±1 % (temperature drift internally compensated)
operating voltage U_B 10 - 30 V DC, reverse polarity protection
voltage ripple ±10 %
no-load current consumption < 40 mA
housing plastic parts: PVDF, PBT; ultrasonic transducer: PTFE, FFKM
ambient pressure up to 0.5 bar over pressure
weight 30 g
max. tightening torque of nuts 1 Nm
class of protection per EN 60 529 IP 67
type of connection 5-pin M12 circular plug
controls Teach-in via pin 5 (Com)
indicators LED green (operation)
 LED yellow (state of output)
programmable Teach-in, LinkControl
synchronisation internal synchronisation up to 10 sensors
operating temperature -25°C to +70°C
storage temperature -40°C to +85°C
switched output Push-Pull, U_B -3 V, -U_B +3 V, I_{max} = 100 mA
 switchable NOC/NCC, short-circuit-proof
switching hysteresis 1) 2 mm
switching frequency 1) 25 Hz
response time 1) 32 ms
time delay before availability 1) < 300 ms
norm conformity EN 60947-5-2

order no. pico+15/TF/F

1) Can be programmed with LinkControl

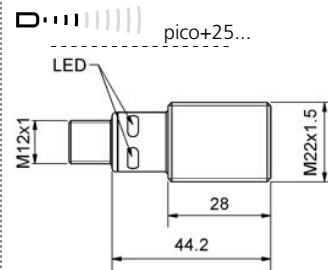

30 mm
 250 mm
 350 mm
 see detection zone
 320 kHz
 0.069 mm
 ± 0.15 %

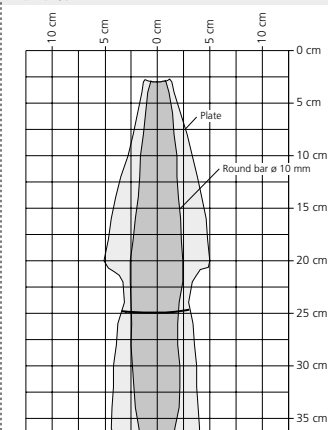

accuracy ±1 % (temperature drift internally compensated)
operating voltage U_B 10 - 30 V DC, reverse polarity protection
voltage ripple ±10 %
no-load current consumption < 40 mA
housing plastic parts: PVDF, PBT; ultrasonic transducer: PTFE, FFKM
ambient pressure up to 0.5 bar over pressure
weight 30 g
max. tightening torque of nuts 1 Nm
class of protection per EN 60 529 IP 67
type of connection 5-pin M12 circular plug
controls Teach-in via pin 5 (Com)
indicators LED green (operation)
 LED yellow (state of output)
programmable Teach-in, LinkControl
synchronisation internal synchronisation up to 10 sensors
operating temperature -25°C to +70°C
storage temperature -40°C to +85°C
switched output Push-Pull, U_B -3 V, -U_B +3 V, I_{max} = 100 mA
 switchable NOC/NCC, short-circuit-proof
switching hysteresis 3 mm
switching frequency 25 Hz
response time 32 ms
time delay before availability < 300 ms
norm conformity EN 60947-5-2

order no. pico+25/TF/F

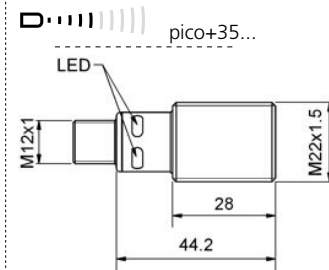

70 mm
 350 mm
 600 mm
 see detection zone
 400 kHz
 0.069 mm
 ± 0.15 %

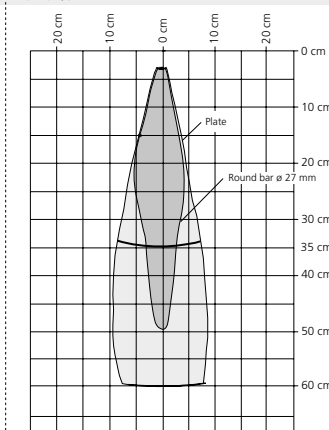

accuracy ±1 % (temperature drift internally compensated)
operating voltage U_B 10 - 30 V DC, reverse polarity protection
voltage ripple ±10 %
no-load current consumption < 40 mA
housing plastic parts: PVDF, PBT; ultrasonic transducer: PTFE, FFKM
ambient pressure up to 0.5 bar over pressure
weight 30 g
max. tightening torque of nuts 1 Nm
class of protection per EN 60 529 IP 67
type of connection 5-pin M12 circular plug
controls Teach-in via pin 5 (Com)
indicators LED green (operation)
 LED yellow (state of output)
programmable Teach-in, LinkControl
synchronisation internal synchronisation up to 10 sensors
operating temperature -25°C to +70°C
storage temperature -40°C to +85°C
switched output Push-Pull, U_B -3 V, -U_B +3 V, I_{max} = 100 mA
 switchable NOC/NCC, short-circuit-proof
switching hysteresis 5 mm
switching frequency 12 Hz
response time 64 ms
time delay before availability < 300 ms
norm conformity EN 60947-5-2

order no. pico+35/TF/F

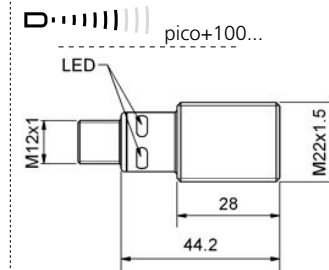

120 mm
 1,000 mm
 1,300 mm
 see detection zone
 200 kHz
 0.069 mm
 ± 0.15 %

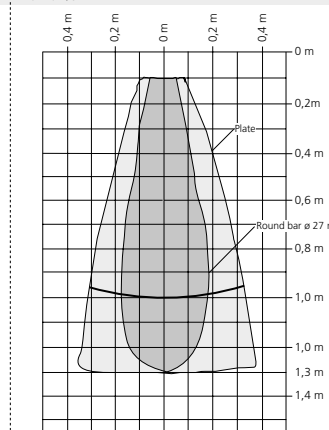

accuracy ±1 % (temperature drift internally compensated)
operating voltage U_B 10 - 30 V DC, reverse polarity protection
voltage ripple ±10 %
no-load current consumption < 40 mA
housing plastic parts: PVDF, PBT; ultrasonic transducer: PTFE, FFKM
ambient pressure up to 0.5 bar over pressure
weight 30 g
max. tightening torque of nuts 1 Nm
class of protection per EN 60 529 IP 67
type of connection 5-pin M12 circular plug
controls Teach-in via pin 5 (Com)
indicators LED green (operation)
 LED yellow (state of output)
programmable Teach-in, LinkControl
synchronisation internal synchronisation up to 10 sensors
operating temperature -25°C to +70°C
storage temperature -40°C to +85°C
switched output Push-Pull, U_B -3 V, -U_B +3 V, I_{max} = 100 mA
 switchable NOC/NCC, short-circuit-proof
switching hysteresis 20 mm
switching frequency 10 Hz
response time 80 ms
time delay before availability < 300 ms
norm conformity EN 60947-5-2

order no. pico+100/TF/F

be within the range of 0-85 % of the set distance.

- In the »Set detect point – method A« Teach-in procedure the actual distance to the object is taught to the sensor as the detect point. If the object moves towards the sensor (e.g. with level control) then the taught distance is the level at which the sensor has to switch the output.
- If the object to be scanned moves into the detection area from the side, the »Set detect point +8 % – method B« Teach-in procedure should be used. In this way the switching distance is set 8 % further than the actual measured distance to the object. This ensures a reliable switching distance even if the height of the objects varies slightly.

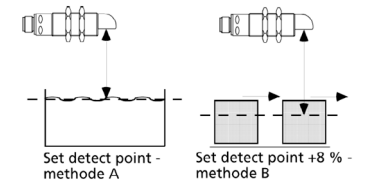

Fig. 4: Setting the detect point for different directions of movement of the object

- If synchronization is activated the Teach-in is disabled (see »Further settings«).
- The sensor can be reset to its factory setting (see »Further settings«).
- Using the LinkControl adapter (optional accessory) and the LinkControl software for Windows, all Teach-in and additional sensor parameter settings can be optionally undertaken.



IO-Link mode

IO-Link mode

The pico+ sensors are IO-Link-capable in accordance with IO-Link specification V1.0.

Pointer

- In IO-Link mode Teach-in, LinkControl and synchronization via pin 5 are not available.
- In IO-Link mode pin 5 must not be connected to any potential.
- For current information about IO-Link please contact the microsonic sales department.

Synchronisation in IO-Link mode

In IO-Link mode each sensor is synchronized on the protocol of the IO-Link master.

In multiple sensor operation the sensors are synchronous if the master protocols are synchronous.

Process data

The pico+ cyclically transmits the measured distance value with a resolution of 0,1 mm and the state of

the switched output.

Service data

The following sensor parameters may be set via IO-Link interface using the IO-Link device description (IODD).

Detect point 1

The switched output is activated when the distance to an object is under that of the present detect point.

Return detect point 1

The switched output is reactivated when the distance to an object is greater than the present return detect point (detect point + hysteresis).

Pointer

- The return detect point 1 must always be greater than the detect point 1.

Detect point 2, return detect point 2

By programming these two detect distances the window mode is activated.

Pointer

- The return detect point 2 must always be smaller than the detect point 2.

NOC/NCC operation

The NCC or NOC output function can be present for the switched output.

Measurement filter

pico+ ultrasonic sensors provide for a choice of 3 filter settings:

- F00
No filter, each ultrasonic measurement acts in an unfiltered manner on the output.
- F01
Standard filter, on the object continuously approaching the sensor, the ongoing interval is immediately taken on and the output correspondingly activated. The effect of the object abruptly moving away from the sensor is for the existing distance to be saved for a retaining time dependent on the filter strength and for the switched

output state to be maintained.

- F02
Average value filter, forms the arithmetic mean across a number of measurements. The output is activated in keeping with the average value. The number of measurements, from which the average value is formed, depends on the selected filter strength.

Filter strength

A filter strength between 0 – weak filter effect – and 9 – pronounced filter effect – can be selected for each measurement filter.

Foreground suppression

Spurious reflections, caused by objects in the foreground of the sensor may be blocked out by the foreground suppression.

Pointer

- Check that the object in the foreground does not cause multiple reflections.

- The object in the foreground must not cover the sensor in a way that the detection zone is influenced.

System commands

With 4 system commands the following settings may be carried out:

- Teach-in detect point – method A.
- Teach-in detect point – method B.
- Teach-in two way reflective barrier.
- Reset sensor to factory settings.

Pointer

To achieve the maximum resolution the Master Cycle Time has to comply with the following requirements:

- Min Cycle Time ≤ Master Cycle Time ≤ Min Cycle Time + 1.2 ms.
- If this condition can not be fulfilled, sporadic discontinuities of the measurement value can occur. In this case the Master Cycle Time has to be increased in 400 µs steps until the discontinuities of the measurement disappear.

Pointer

- If the pico+ sensor was set using Teach-in or LinkControl it is recommended to reset the sensor to the factory setting prior to using it in IO-Link mode (s. »Further settings«).

IODD file

The latest IODD file you will find on the internet under www.microsonic.de/en/IODD.

For further informations on IO-Link see www.io-link.com.

IO-Link data

	pico+15...			pico+25...			pico+35...			pico+100...		
physical layer	yes			yes			yes			yes		
SIO mode support	8.4 ms			8.4 ms			16 ms			20.4 ms		
min cycle time	COM 2 (38.400 Bd)			COM 2 (38.400 Bd)			COM 2 (38.400 Bd)			COM 2 (38.400 Bd)		
baud rate	16 Bit, R, UNI16			16 Bit, R, UNI16			16 Bit, R, UNI16			16 Bit, R, UNI16		
format of process data	Bit 0: state of switched output; Bit 1-15: distance value with 0,1 mm resolution			Bit 0: state of switched output; Bit 1-15: distance value with 0,1 mm resolution			Bit 0: state of switched output; Bit 1-15: distance value with 0,1 mm resolution			Bit 0: state of switched output; Bit 1-15: distance value with 0,1 mm resolution		
content of process data												
service data IO-Link specific	index	access	value	index	access	value	index	access	value	index	access	value
Vendor name	0x10	R	microsonic GmbH	0x10	R	microsonic GmbH	0x10	R	microsonic GmbH	0x10	R	microsonic GmbH
Vendor text	0x11	R	www.microsonic.de	0x11	R	www.microsonic.de	0x11	R	www.microsonic.de	0x11	R	www.microsonic.de
Product name	0x12	R	pico+	0x12	R	pico+	0x12	R	pico+	0x12	R	pico+
Product ID	0x13	R	15/F;15/WK/F	0x13	R	25/F;25/WK/F	0x13	R	35/F;35/WK/F	0x13	R	100/F;100/WK/F
Product text	0x14	R	Ultraschall-Sensor	0x14	R	Ultraschall-Sensor	0x14	R	Ultraschall-Sensor	0x14	R	Ultraschall-Sensor
service data sensor specific	index	format	access	range (dez)	index	format	access	range (dez)	index	format	access	range (dez)
detect point 1	0x40	UINT16	R/W	306-3,609 (21-248 mm) 1)	0x40	UINT16	R/W	436-5,065 (30 - 348 mm) 1)	0x40	UINT16	R/W	946-8,704 (65 - 598 mm) 1)
return detect point 1	0x41	UINT16	R/W	320-3,624 (22-249 mm) 1)	0x41	UINT16	R/W	451-5,080 (31 - 349 mm) 1)	0x41	UINT16	R/W	961-8,718 (66 - 599 mm) 1)
detect point 2	0x47	UINT16	R/W	335-65,512 (23 - 250 mm) 1)	0x47	UINT16	R/W	466-65,512 (32 - 350 mm) 1)	0x47	UINT16	R/W	975-65,512 (67 - 600 mm) 1)
return detect point 2	0x48	UINT16	R/W	> 3,638: window mode deactivated 320-65,512 (22 - 250 mm) 1)	0x48	UINT16	R/W	> 5,094: window mode deactivated 451-65,512 (31 - 349 mm) 1)	0x48	UINT16	R/W	> 8,733: window mode deactivated 961-65,512 (66 - 599 mm) 1)
switching mode	0x42	UINT8	R/W	00: NCC, 02: NOC	0x42	UINT8	R/W	00: NCC, 02: NOC	0x42	UINT8	R/W	00: NCC, 02: NOC
filter	0x43	UINT8	R/W	00-02: F00 - F02	0x43	UINT8	R/W	00-02: F00 - F02	0x43	UINT8	R/W	00-02: F00 - F02
filter strength	0x44	UINT8	R/W	00-09: P00 - P09	0x44	UINT8	R/W	00-09: P00 - P09	0x44	UINT8	R/W	00-09: P00 - P09
foreground suppression	0x49	UINT16	R/W	0-1,878 (0-129 mm) 1)	0x49	UINT16	R/W	0-3,246 (0-223 mm) 1)	0x49	UINT16	R/W	0-4,236 (0-291 mm) 1)
Teach-in via Pin 5 in SIO mode	0x4A	UINT8	R/W	00: deactivated, 16: activated	0x4A	UINT8	R/W	00: deactivated, 16: activated	0x4A	UINT8	R/W	00: deactivated, 16: activated
system commands	index	access	value	index	access	value	index	access	value	index	access	value
Teach-in detect point – method A	0x02	W	161	0x02	W	161	0x02	W	161	0x02	W	161
Teach-in detect point – method B	0x02	W	162	0x02	W	162	0x02	W	162	0x02	W	162
Teach-in two way reflective barrier	0x02	W	164	0x02	W	164	0x02	W	164	0x02	W	164
reset to factory settings	0x02	W	168	0x02	W	168	0x02	W	168	0x02	W	168

¹⁾ Distance values, e.g. detect points, are given as multiple of the internal resolution of the measurement value = 0,069 mm (example: 320 ÷ 22 mm). The values in the table are decimal.