



Operating Instructions

Ultrasonic proximity switch with one switched output and IO-Link interface

- pms-15/CF/A1
- pms-25/CF/A1
- pms-35/CF/A1
- pms-100/CF/A1

Product description

The pms sensor has a stainless steel housing and is designed for applications with hygienic requirements. The ultrasonic transducer surface of the pms sensors is laminated with a PTFE film. The transducer itself is sealed against the housing by a joint ring made of FKM.

The pms sensor with D12 adapter shaft can be fitted in a mounting clip which meets hygiene standards like the sensor screw connection BF-pms/A1. The special housing design ensures that any cleaning fluids are able to run off completely, regardless of the installation situation. The pms sensor is ECOLAB and EHEDG certified. The pms sensor offers a non-contact measurement of the distance to an object present within the sensors's detection zone. The switched output is set conditional upon

the adjusted detect distance.

For sensor setting, the accessory LinkControl adapter LCA-2 is recommended in combination with LinkControl software for Windows®. Alternatively, the sensor can also be set by Teach-in via pin 2.

The pms sensors are IO-Link-capable in accordance with IO-Link specification V1.1.

Safety Notes

- Read the operating instructions prior to start-up.
- Connection, installation and adjustment works should be carried out by skilled personnel only.
- No safety component in accordance with the EU Machine Directive.

Proper Use

pms ultrasonic sensors are used for

non-contact detection of objects. The sensor must be mounted in an EHEDG-approved mounzing clip, such as the sensor screw connection BF-pms/A1 for a EHEDG-compliant use.

Installation

- Assemble the sensor and its hygienic D12 sensor screw connection BF-pms/A1 or an equivalent sensor mounting clip at the installation location.
- Pull sensor cable through the sensor gland, connect it to the M8 sensor plug, see. fig. 1.
- Push the sensor with its shaft into the sensor screw connection BF-pms/A1 and adjust (see figure 4-6). Tighten with lock nut (maximum tightening torque 12 Nm).

		colour
1	+U _B	brown
3	-U _B	blue
4	F	black
2	Com	white

Fig. 1: Pin assignment with view onto sensor plug and colour coding of the microsonic connection cables

Start-up

- Connect the power supply.
- Carry out sensor adjustment with LinkControl or alternatively Teach-in procedure in accordance with the diagram.

Factory Setting

- Detect point operation
- Switched output on NOC
- Detect distance at operating range

- Filter at F01
- Filter strength at P00

Operating Modes

Four operating modes are available for the switched output:

- Operation with one detect point
respective one detect point + 8%
The switched output is set when the object falls below the set detect point.
- Window mode
The switched output is set when the object is within the set window.
- Two-way reflective barrier
The switched output is set when the object is between sensor and fixed reflector.

	□ ·····	□ — □
pms-15	≥ 0.25 m	≥ 1.30 m
pms-25	≥ 0.35 m	≥ 2.50 m
pms-35	≥ 0.40 m	≥ 2.50 m
pms-100	≥ 0.70 m	≥ 4.00 m

Fig. 2: Assembly distances

Maintenance

microsonic sensors are maintenance-free. For cleaning in areas with hygienic requirements, access to the sensor must be guaranteed from all EHEDG. The pms sensor is ECOLAB certified. The listed cleaning agents (see ECOLAB certificate) can be used to clean the sensors. Other cleaing agents must be tested first before usage in order to determine whether the sensor (stainless steel, FKM, PTFE) is resistant to them. Cleaning is permitted up to a cleaning temperature of 85°C. Do not use a high-pressure cleaner to clean the sensor. Caking of the sensor membrane must not be removed with sharp objects. The sensor membrane must not be damaged.

Notes

- The sensors of the pms family have a blind zone, within which a distance measurement is not possible.
- If several pms sensors are operated

Contact

Sensor Partners BV

- James Wattlaan 15
5151 DP Drunen
The Netherlands
- +31 (0)416 - 37 82 39
- info@sensorpartners.com
- sensorpartners.com

Sensor Partners BVBA

- Z.1 Researchpark 310
B-1731, Zellik
Belgium
- +32 (0)2 - 464 96 90
- info@sensorpartners.com
- sensorpartners.com

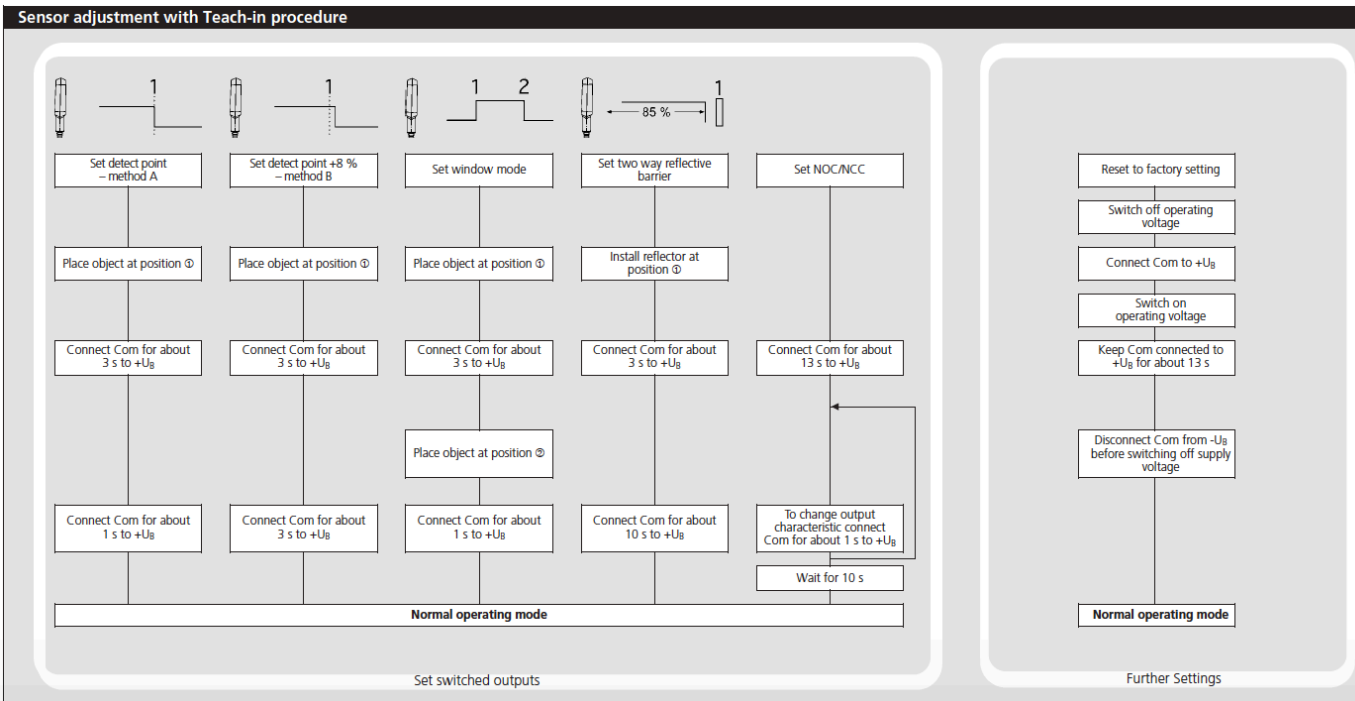

Technical data

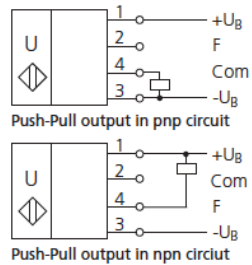

blind zone
operating range
maximum range
angle of beam spread
transducer frequency
resolution
reproducibility

detection zones
 for different objects:
 The dark grey areas represent the zone where it is easy to recognise the normal reflector (round bar). This indicates the typical operating range of the sensors. The light grey areas represent the zone where a very large reflector – for instance a plate – can still be recognized. The requirement here is for an optimum alignment to the sensor. It is not possible to evaluate ultrasonic reflections outside this area.

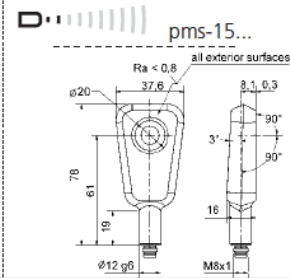

20 mm
 150 mm
 250 mm
 see detection zone
 380 kHz
 0.069 mm
 ± 0.15 %

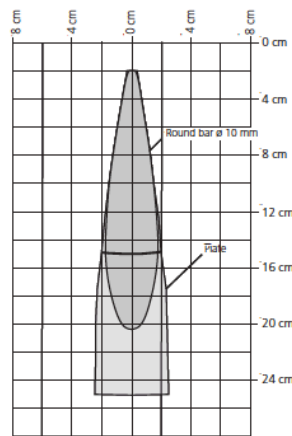

accuracy
operating voltage U_B
voltage ripple
no-load current consumption
housing
ECOLAB
EHDG
class of protection per EN 60 529
norm conformity
type of connection
controls
programmable
operating temperature
storage temperature
switched output
switching hysteresis¹⁾
switching frequency¹⁾
response time¹⁾
time delay before availability¹⁾
weight

± 1 % (temperature drift internally compensated)
 10 - 30 V DC, reverse polarity protection (Class 2)
 ± 10 %
 < 40 mA
 stainless steel 1.4404/316L;
 ultrasonic transducer: PTFE, FKM
 yes
 yes, TYPE EL CLASS I AUX
 IP 66, IP 67, IP 68
 EN 60947-5-2
 4-pin M8 initiator plug
 Teach-in via pin 2 (Com)
 Teach-in, LinkControl
 -25°C to +70°C
 -40°C to +85°C
 Push-Pull, U_B-3 V, -U_B+3 V, I_{max} = 100 mA
 switchable NOC/NCC, short-circuit-proof
 2 mm
 25 Hz
 32 ms
 < 300 ms
 140 g

order no. pms-15/CF/A1

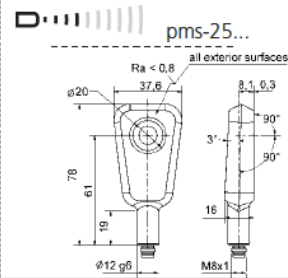

30 mm
 250 mm
 350 mm
 see detection zone
 320 kHz
 0.069 mm
 ± 0.15 %

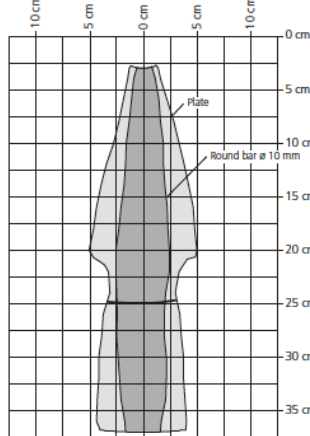

± 1 % (temperature drift internally compensated)
 10 - 30 V DC, reverse polarity protection (Class 2)
 ± 10 %
 < 40 mA
 stainless steel 1.4404/316L;
 ultrasonic transducer: PTFE, FKM
 yes
 yes, TYPE EL CLASS I AUX
 IP 66, IP 67, IP 68
 EN 60947-5-2
 4-pin M8 initiator plug
 Teach-in via pin 2 (Com)
 Teach-in, LinkControl
 -25°C to +70°C
 -40°C to +85°C
 Push-Pull, U_B-3 V, -U_B+3 V, I_{max} = 100 mA
 switchable NOC/NCC, short-circuit-proof
 3 mm
 25 Hz
 32 ms
 < 300 ms
 140 g

order no. pms-25/CF/A1

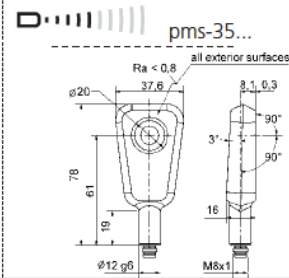

65 mm
 350 mm
 600 mm
 see detection zone
 400 kHz
 0.069 mm
 ± 0.15 %

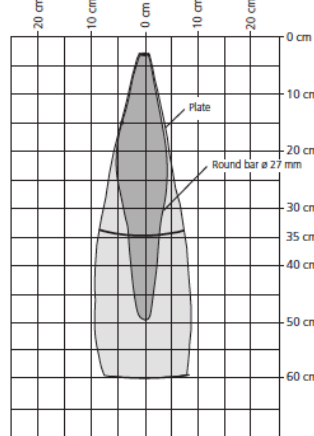

± 1 % (temperature drift internally compensated)
 10 - 30 V DC, reverse polarity protection (Class 2)
 ± 10 %
 < 40 mA
 stainless steel 1.4404/316L;
 ultrasonic transducer: PTFE, FKM
 yes
 yes, TYPE EL CLASS I AUX
 IP 66, IP 67, IP 68
 EN 60947-5-2
 4-pin M8 initiator plug
 Teach-in via pin 2 (Com)
 Teach-in, LinkControl
 -25°C to +70°C
 -40°C to +85°C
 Push-Pull, U_B-3 V, -U_B+3 V, I_{max} = 100 mA
 switchable NOC/NCC, short-circuit-proof
 5 mm
 12 Hz
 64 ms
 < 300 ms
 140 g

order no. pms-35/CF/A1

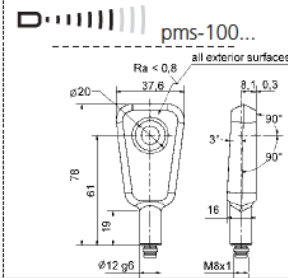

120 mm
 1,000 mm
 1,300 mm
 see detection zone
 200 kHz
 0.069 mm
 ± 0.15 %

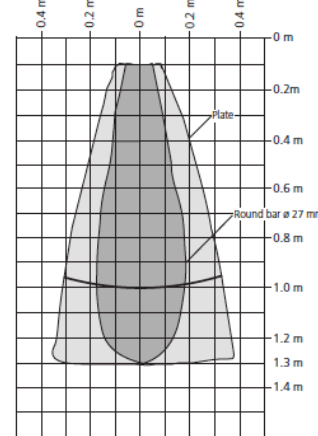

± 1 % (temperature drift internally compensated)
 10 - 30 V DC, reverse polarity protection (Class 2)
 ± 10 %
 < 40 mA
 stainless steel 1.4404/316L;
 ultrasonic transducer: PTFE, FKM
 yes
 yes, TYPE EL CLASS I AUX
 IP 66, IP 67, IP 68
 EN 60947-5-2
 4-pin M8 initiator plug
 Teach-in via pin 2 (Com)
 Teach-in, LinkControl
 -25°C to +70°C
 -40°C to +85°C
 Push-Pull, U_B-3 V, -U_B+3 V, I_{max} = 100 mA
 switchable NOC/NCC, short-circuit-proof
 20 mm
 10 Hz
 80 ms
 < 300 ms
 140 g

order no. pms-100/CF/A1

in a small space, the minimum mounting for parallel or opposite arrangement of the sensors shown in figure 2 must be maintained.

- The pms sensors are equipped with an internal temperature compensation. Due to the sensors self heating, the temperature compensation reaches its optimum working-point after approx. 45 seconds of operation.
- The sensor can be reset to its factory setting (see »Further settings«).
- With the two-way reflective barrier the object may be in the range of 0-85% of the teach-in distance.
- In the »Set detect point – method A« Teach-in procedure the actual distance to the object is taught to the sensor as the detect point. If the object moves towards the sensor (e.g. with level control) then the taught distance is the level at which the sensor has to switch the output.
- If the object to be scanned moves into the detection area from the side, the »Set detect point +8 % – method B« Teach-in procedure should be used. In this way the switching distance is set 8 % further than the actual measured distance to the object. This ensures a reliable switching distance even if the height of the objects varies slightly, see fig. 3.

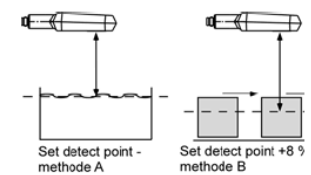

Fig. 3: Setting the detect point for different directions of movement of the object

- For Teach-in procedure when using the LinkControl adapter (optional accessory) the additional adapter 5G/M12-4G/M12/M8 is needed.

1) Can be programmed with LinkControl

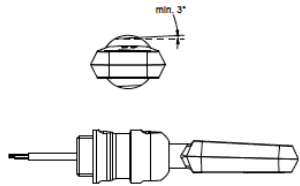

Fig. 4: pms sensor D12-adapter shaft with sensor screw connection BF-pms/A1, all surfaces must be inclined at least 3°.

- If the sensor is cleaned wet, all surfaces must be inclined at least 3° from the horizontal alignment so that the cleaning agents can run off completely (see figure 4-6). There is a risk that condensate or dripping water might drip from the sensor and mounting brackets into the product area.

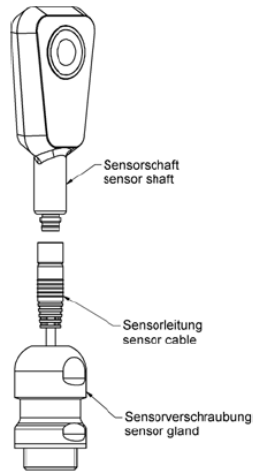

Fig. 5: Mounting of pms sensor with sensor screw connection BF-pms/A1

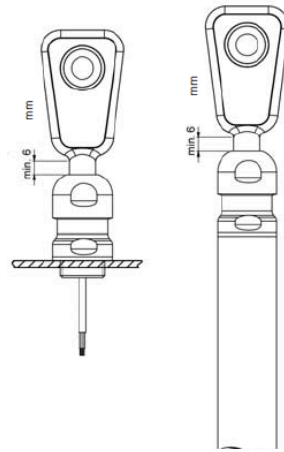

Fig. 6: pms sensor D12 adapter shaft with sensor screw connection BF-pms/A1 mounted to machine part or to stainless steel tube D26.8 with internal thread M20x1.5

- The D12 adapter shaft of the pms sensor has to stick out at least 6 mm from the screw connection (see figure 4-6).
- The sealing ring has to fill space between D12 sensor shaft and cap nut. Sealing ring should not to be pressed out excessively from the shaft gland.

Mounting accessory

- D12 sensor screw connection BF-pms/A1

Accessory for programming

- LinkControl adapter LCA-2
- Adapter 5G/M12-4G/M12/M8

IO-Link mode

The pms sensors are IO-Link-capable in accordance with IO-Link specification V1.1.

Note

In IO-Link mode LinkControl and synchronization via pin 2 are not available.

Smart Sensor Profile

Die pms sensors support the Smart Sensor Profile. The following profiles and function classes are integrated:

- 0x000A - Device Profil: Digital measuring sensors
- 0x8000 - Device Identification
- 0x8001 - Multichannel: two setpoint switching sensor
- 0x8003 - Device Diagnosis
- 0x8004 - Teach Channel
- 0x800A - Measurement Data Channel (standard resolution)

System Commands

With 3 system commands the following settings may be carried out:

- Teach-in SP1

- Teach-in SP2
- Reset sensor to factory settings

SSC1 Configuration

In IO-Link mode the pms sensor has 5 operating modes:

- Single point (SP1: switching point)
- Window (SP1, SP2: window mode)
- Two point (SP1, SP2: hysteresis mode)
- Single point +8 % (SP1 switching point +8 %)
- Window ±8 % (SP1 two way reflective barrier)

IODD File

The latest IODD and further information about start-up of pms sensors with IO-Link, you will find online at www.microsonic.de/pms.



IO-Link data																					
		pms-15...					pms-25...					pms-35...					pms-100...				
Physical layer	SIO mode support	yes					yes					yes					yes				
	min cycle time	8 ms					8 ms					16 ms					20 ms				
	baud rate	COM 2 (38.400 Bd)					COM 2 (38.400 Bd)					COM 2 (38.400 Bd)					COM 2 (38.400 Bd)				
format of process data	format of process data	Frametype 2_V, 4 Byte					Frametype 2_V, 4 Byte					Frametype 2_V, 4 Byte					Frametype 2_V, 4 Byte				
	content of process data	Bit 0: state of switched output, Bit 8-15: scale (Int. 8), Bit 16-31: measured value (Int. 16) with 0,1 mm resolution					Bit 0: state of switched output, Bit 8-15: scale (Int. 8), Bit 16-31: measured value (Int. 16) with 0,1 mm resolution					Bit 0: state of switched output, Bit 8-15: scale (Int. 8), Bit 16-31: measured value (Int. 16) with 0,1 mm resolution					Bit 0: state of switched output, Bit 8-15: scale (Int. 8), Bit 16-31: measured value (Int. 16) with 0,1 mm resolution				
Identification features	Vendor name	microsonic GmbH					microsonic GmbH					microsonic GmbH					microsonic GmbH				
	Vendor ID	419 (0x01A3)					419 (0x01A3)					419 (0x01A3)					419 (0x01A3)				
	Product name	pms-15/CF/A1					pms-25/CF/A1					pms-35/CF/A1					pms-100/CF/A1				
	Product ID	35000					35100					35200					35300				
	Device ID	29 (0x00001D)					30 (0x00001E)					31 (0x00001F)					32 (0x000020)				
SSC1 configuration	Parameter	index	subindex	format	access	range	index	subindex	format	access	range	index	subindex	format	access	range	index	subindex	format	access	range
	SP1 (Setpoint 1)	60	1	UINT16	R/W	20 - 250 ¹⁾	60	1	UINT16	R/W	30 - 350 ¹⁾	60	1	UINT16	R/W	65 - 600 ¹⁾	60	1	UINT16	R/W	120 - 1300 ¹⁾
	SP2 (Setpoint 2)	60	2	UINT16	R/W	20 - 250 ¹⁾	60	2	UINT16	R/W	30 - 350 ¹⁾	60	2	UINT16	R/W	65 - 600 ¹⁾	60	2	UINT16	R/W	120 - 1300 ¹⁾
	Hysteresis	61	3	INT8	R/W	0,1 - 230 ¹⁾	61	3	UINT8	R/W	0,1 - 320 ¹⁾	61	3	UINT8	R/W	0,1 - 535 ¹⁾	61	3	UINT8	R/W	0,1 - 1180 ¹⁾
SSC1 configuration	Logic Mode	61	1	UINT16	R/W	0: High active, 1: Low active															
	Teach-In	61	2	UINT8	R/W	1: single point (SP1: switching point), 2: window (SP1, SP2: window mode), 3: two point (SP1, SP2: hysteresis mode), 128: single point +8 % (SP1: switching point +8 %), 129: window ±8 % (SP1: two way reflective barrier)															
Teach-In	Teach-In channel	58		UINT8	R/W	0: SSC1: Pin 4 (Push-Pull)															
	Teach-In status	59		UINT8	RO	Bit 0-3: 0: idle, 1: SP1 success, 2: SP2 success, 7: error; Bit 4: SP1 TP1; Bit 6: SP2 TP1															
	SP1 single value teach-in	2		UINT8	WO	65: The value 65 must be written to index 2 to trigger the command.															
Filter	SP2 single value teach-in	2		UINT8	WO	66: The value 66 must be written to index 2 to trigger the command.															
	Type	256		UINT8	R/W	0-4: F00 (no filter), F01 (standard filter), F02 (averaging filter), F03 (foreground filter), F04 (background filter)															
	Strength	256		UINT8	R/W	0-9: P00 - P09; For each measurement filter a filter strength between 0, weak filter effect, and 9, strong filter effect, can be chosen.															
Temperature compensation	Mode	300	1	UINT8	R/W	0: off, 1: on															
Factory settings	FactorySettings	2		UINT8	WO	130: The value130 must be written to index 2 to trigger the command.															
	DeviceaccessLocks	12		UINT16	R/W	Bit 0: parameter (write) access lock; Bit 2: local user interface lock															

1) Distance value, e.g. setpoints, are give with a resolutin of 0,1 mm. The values in the tables are decimal.