

CX2 series

DATASHEET

Sensor Partners BV

📍 James Wattlaan 15
5151 DP Drunen
The Netherlands

☎ +31 (0)416 - 37 82 39

✉ info@sensorpartners.com

🌐 sensorpartners.com

Sensor Partners BVBA

📍 Z.1 Researchpark 310
B-1731, Zellik
Belgium

☎ +32 (0)2 - 464 96 90

✉ info@sensorpartners.com

🌐 sensorpartners.com

CX2 series

Area sensors with high resolution and compact housing with digital and analogue output

features

- Parallel beams and floating crossbeams with variable amplitude
- Synchronization by cable. Pitch 5, 10 and 20mm
- Control height up 480mm (pitch 5mm) and up 960mm (pitch 10mm and 20mm)
- Maximum operating distance up to 3m (for 5mm pitch) and 6m (for 10mm and 20mm pitch)
- Digital outputs NPN and PNP ; analogue current output (4...20mA) and analogue voltage output (0..10V), mix outputs : digital PNP and analogue voltage output (0..10V)
- Adjustment by teach-in , 2 levels of adjustment
- Blanking function . Available analogue versions TOP BEAM

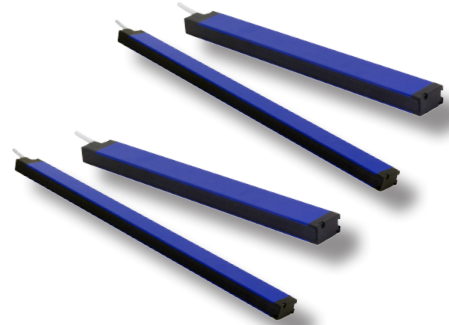

code description

	CX2	E	0	R	B	/	05	-	016	V	
series	CX2	Area Sensor cubic section									
emitter	E	Emitter									
emitter type	0	Emitter with I/O standard configuration									
receiver	R	Receiver									
receiver type	A	Receiver with two analogue outputs (voltage 0...10 V and current 4...20 mA)									
	B	Receiver with two digital outputs (NPN and PNP)									
	F	Receiver with one digital output PNP and one analogue output (voltage 0...10 V)									
pitch	05	Pitch 5 mm									
	10	Pitch 10 mm									
	20	Pitch 20 mm									
height	016	Controlled height 160 mm									
	032	Controlled height 320 mm									
	048	Controlled height 480 mm									
	064	Controlled height 640 mm									
	080	Controlled height 800 mm									
output	096	Controlled height 960 mm									
	V	Output cable length 220 mm with M12 pigtail									
special function	TB	Analogue reading last led TOP BEAM (CX2RA)									

available models

OUTPUT			INPUT			beams number	pitch (mm)	plot (P/I) ⁽¹⁾	working range (m)	detection height	KIT (E + R)						
state	logic	output	blanking	test	adjustment												
NO/NC	NPN + PNP					33	5	I/P	0.3...3	160 mm	CX2E0RB/05-016V						
						65		P		320 mm	CX2E0RB/05-032V						
						97				480 mm	CX2E0RB/05-048V						
						17	10	I/P	0.3...6	160 mm	CX2E0RB/10-016V						
						33				320 mm	CX2E0RB/10-032V						
						49				480 mm	CX2E0RB/10-048V						
						65				640 mm	CX2E0RB/10-064V						
						81				800 mm	CX2E0RB/10-080V						
						97				960 mm	CX2E0RB/10-096V						
						9	20	P	0.3...6	160 mm	CX2E0RB/20-016V						
						17				320 mm	CX2E0RB/20-032V						
						25				480 mm	CX2E0RB/20-048V						
						33				640 mm	CX2E0RB/20-064V						
						41				800 mm	CX2E0RB/20-080V						
						49				960 mm	CX2E0RB/20-096V						
						33	5	P	0.3...3	160 mm	CX2E0RA/05-016V						
						65				320 mm	CX2E0RA/05-032V						
						97				480 mm	CX2E0RA/05-048V						
	17	10	P	0.3...6	160 mm	CX2E0RA/10-016V											
	33				320 mm	CX2E0RA/10-032V											
	49				480 mm	CX2E0RA/10-048V											
	65				640 mm	CX2E0RA/10-064V											
	81				800 mm	CX2E0RA/10-080V											
	97				960 mm	CX2E0RA/10-096V											
	9	20	P	0.3...6	160 mm	CX2E0RA/20-016V											
	17				320 mm	CX2E0RA/20-032V											
	25				480 mm	CX2E0RA/20-048V											
	33				640 mm	CX2E0RA/20-064V											
	41				800 mm	CX2E0RA/20-080V											
	49				960 mm	CX2E0RA/20-096V											
	33	analog voltage output + analog current output	2	●	●	Teach-In	33	5	I/P	0.3...3	160 mm	CX2E0RF/05-016V					
	65						P		320 mm		CX2E0RF/05-032V						
	97								480 mm		CX2E0RF/05-048V						
	17						10	I/P	0.3...6	160 mm	CX2E0RF/10-016V						
	33									320 mm	CX2E0RF/10-032V						
	49									480 mm	CX2E0RF/10-048V						
	65									640 mm	CX2E0RF/10-064V						
	81									800 mm	CX2E0RF/10-080V						
	97									960 mm	CX2E0RF/10-096V						
	9						20	P	0.3...6	160 mm	CX2E0RF/20-016V						
	17									320 mm	CX2E0RF/20-032V						
	25									480 mm	CX2E0RF/20-048V						
	33									640 mm	CX2E0RF/20-064V						
	41									800 mm	CX2E0RF/20-080V						
	49									960 mm	CX2E0RF/20-096V						
	33						PNP + analog voltage output					33	5	I/P	0.3...3	160 mm	CX2E0RF/05-016V
	65											P		320 mm		CX2E0RF/05-032V	
	97													480 mm		CX2E0RF/05-048V	
17	10	I/P	0.3...6	160 mm	CX2E0RF/10-016V												
33				320 mm	CX2E0RF/10-032V												
49				480 mm	CX2E0RF/10-048V												
65				640 mm	CX2E0RF/10-064V												
81				800 mm	CX2E0RF/10-080V												
97				960 mm	CX2E0RF/10-096V												
9	20	P	0.3...6	160 mm	CX2E0RF/20-016V												
17				320 mm	CX2E0RF/20-032V												
25				480 mm	CX2E0RF/20-048V												
33				640 mm	CX2E0RF/20-064V												
41				800 mm	CX2E0RF/20-080V												
49				960 mm	CX2E0RF/20-096V												

⁽¹⁾Plot: P = parallel beams, I = crossed beams

technical specifications

CX2E*R*/**_***V	
	
nominal sensing distance	0.1 ... 3 m (beam pitch 5 mm) 0.3 ... 6 m (beam pitch 10 mm)
emission	850 nm (beam pitch 5mm) 880 nm (beam pitch ≥10mm)
operating voltage	16.8...30 Vdc
ripple	< 1.2 Vpp
power consumption (receiver)	1...2.5 W
power consumption (emitter)	1...3 W
output	1 x PNP, 1 x NPN (CX2E0RB); 1 x analogue voltage output, 1 x analog current output (CX2E0RA); 1 x PNP, 1 X analogue voltage output (CX2E0RF)
output current	< 100 mA
output voltage drop	< 1.5 V @ 100 mA
minimum load resistance	280 Ω
leakage current	≤ 10 µA
tolerated capacitive load	< 0.7 µF
power on delay	< 3 sec ⁽¹⁾
Teach-In	(0.5 x N beams) sec
response time	((0.2 x (N beams - 1)) + 1) x 2 ms
operating temperature	-10°C...55°C
storage temperature	-25°C...60°C
artificial light rejection	IEC EN 60947-5-2
ambient light rejection	IEC EN 60947-5-2
IP mechanical protection	IP67
humidity	95% max (no condensation)
vibrations	IEC EN 60947-5-2
shocks	IEC EN 60947-5-2
cable length	< 20 m
connectors / cables	1 x M12, 4 poles, male (CX2E), 1 x M12, 8 poles, male (CX2R)
housing material	painted aluminium RAL5002
optic materials	PMMA

⁽¹⁾ Power on delay with blanking function: (1 x N beams) sec

MDO (Minimum Detectable Object)

beams	step (mm)	resolution ⁽¹⁾ (mm)	qa 17 beams	qa 32 beams
crossed ⁽²⁾	5	2,5	-	93%
	10	5	93%	
parallel	5	5	-	-
	10	10		
	20	20		

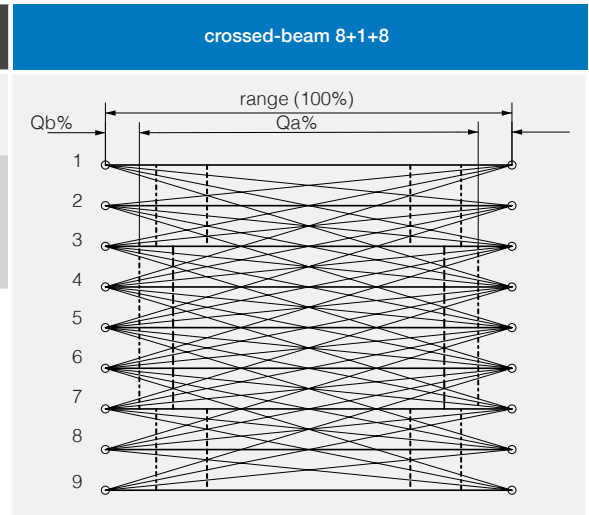

⁽¹⁾ = resolution detected with Teach Gross

⁽²⁾ = the optics cross beam allows detection of objects with a very small diameter or very thin (such as a sheet of paper or an envelope). For those targets with small diameter, the detecting resolution is less effective exactly in the centre between Emitter and Receiver (see Resolution) as well as at the ends of detection area (near to the sensors); the mentioned detection is obtained in the central area Qa with a width equal to a certain % of the distance between the 2 sensors.

plugs

<p>CX2E0/**-**-** emitter with test input</p>	<p>CX2RB/**-**-** receiver with PNP and NPN output</p>
<p>CX2RA/**-**-** receiver with analog output</p>	<p>CX2RF/**-**-** receiver PNP with analog output V</p>

electric diagrams of the connections

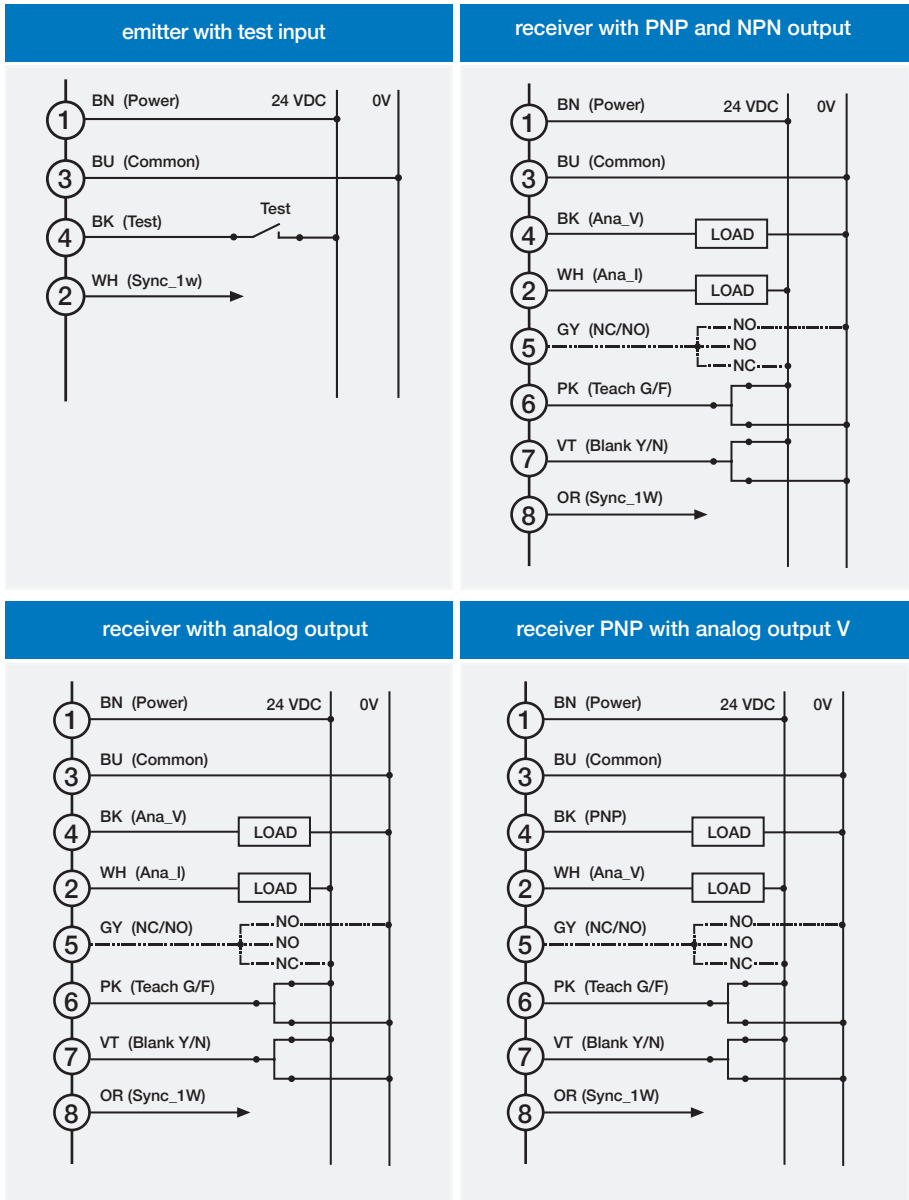

dimensions (mm)

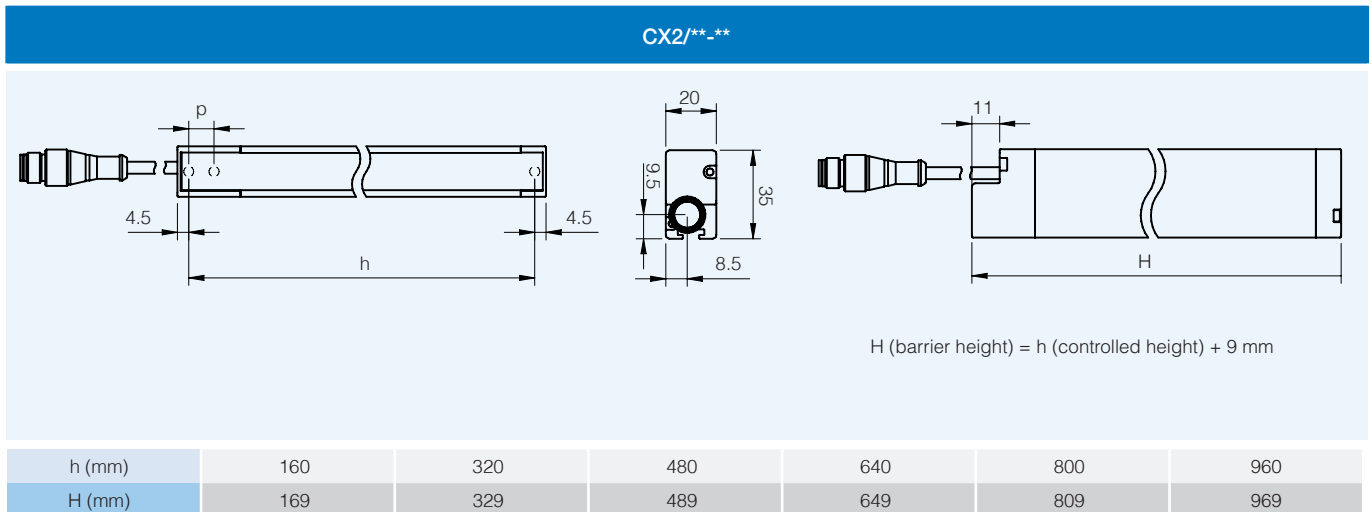

accessories

included with all models

accessories fixing kit ST151

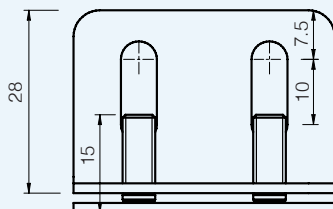
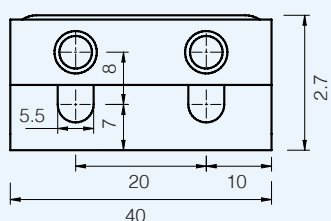

T insert, two M5 nuts and split washers included

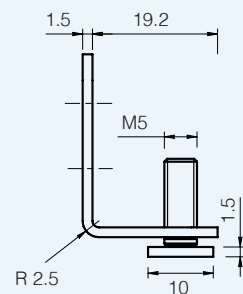

L bracket

code	description
ST4V S	4 pcs. kit antivibration basement for barriers with 150 mm protected height
ST8V S	8 pcs. kit antivibration basement for barriers with protected height from 1,500 mm to 1,050 mm

accessories

not included

code	description
CD12M/0B-050A1	power connector M12, 4 wires, female, axial, cable 5 m PVC
CD12M/0B-100A1	power connector M12, 4 wires, female, axial, cable 10 m PVC
CD12M/0B-150A1	power connector M12, 4 wires, female, axial, cable 15 m PVC
CD12M/0B-050A5	power connector M12, 4 wires, female, axial, cable 5 m PUR
CD12M/0B-100A5	power connector M12, 4 wires, female, axial, cable 10 m PUR
CD12M/0B-150A5	power connector M12, 4 wires, female, axial, cable 15 m PUR
CD12M/0X-050A5	power connector M12, 8 wires, female, axial, cable 5 m PUR
CD12M/0X-100A5	power connector M12, 8 wires, female, axial, cable 10 m PUR
CD12M/0X-150A5	power connector M12, 8 wires, female, axial, cable 15 m PUR