

GLOSS Series

► GLOSS-5-85°

- 85° gloss measurement (for matt surfaces (gloss degree <10 GU)
- Working distance 5 mm ± 10%
- Insensitive to outside light due to clocked white light
- Internal reference (thus optimum light power adjustment to the respective object surface)
- Teaching of up to 7 gloss degrees
- Parameterisable under Windows®
- RS232 interface (USB or Ethernet adapter is available)
- 3 switching outputs (npn-/pnp-able, 100 mA, short circuit proof)
- Transmitter power adjustable or controllable (STAT or DYN)
- Averaging can be activated (over up to approx. 32000 values)
- Scratch-resistance glass cover of optics
- Compact and sturdy aluminum housing
- Digital input IN1 to trigger the analog output value
- Digital input IN0 to trigger the Scope function
- Analog output (0...+10V or 4...20mA, selectable) proportional to gloss degree 0...100 respectively zoomed up to the tenfold with zoom mode
- Calibration function (black glass) by means of calibration unit (optional)
- Offline unit as well as blast-air top available (optional)



Design

Product name:

GLOSS-5-85°

(incl. Windows® software GLOSS-Scope)

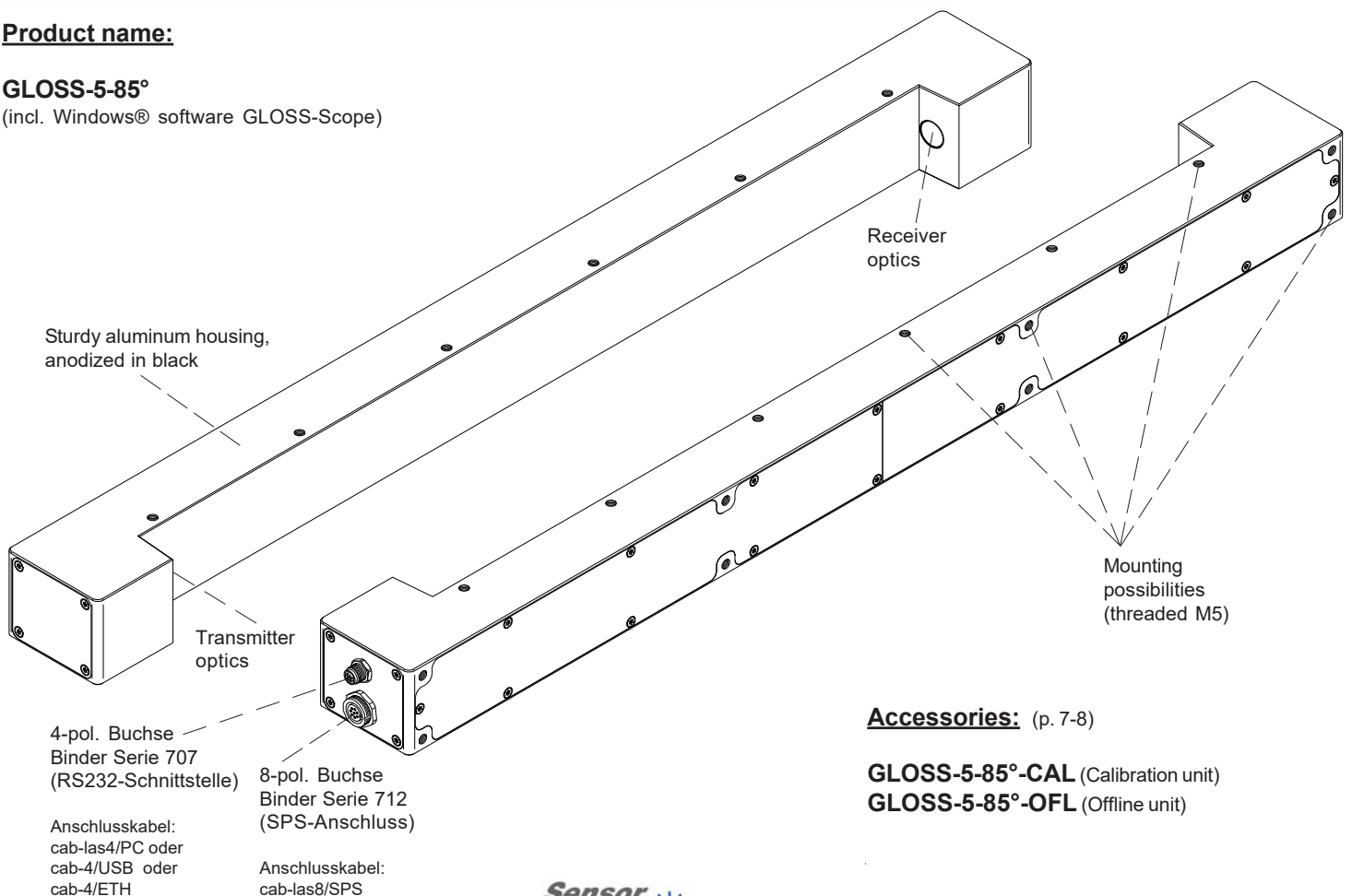

Accessories: (p. 7-8)

GLOSS-5-85°-CAL (Calibration unit)

GLOSS-5-85°-OFL (Offline unit)



Technical Data

Type	GLOSS-5-85°
Light source	White light LED (modulated or direct light, can be adjusted under Windows®)
Working distance	typ. 5 mm ± 10%
Light spot size	at a working distance of 5 mm: typ. 10 mm x 100 mm (elliptical)
Optical filter	day light filter (KG2)
Voltage supply	+24VDC (± 10%), protected against polarity reversal, overload protected
Enclosure rating	IP54
Ambient light	up to 5000 Lux
Current consumption	typ. 100 mA
Interface	RS232, parameterisable under Windows®
EMC test acc. to	DIN EN 60947-5-2
Type of connector	connection to PLC: 8-pole female connector Binder Series 712 connection to PC: 4-pole female connector Binder Series 707
Connecting cables	to PLC: cab-las8/SPS or cab-las8/SPS-w and cab-las4/SPS to PC/RS232 interface: cab-las5/PC or cab-las5/PC-w to PC/USB interface: cab-4/USB or cab-4/USB-w to PC/Ethernet interface: cab-4/ETH
Operating temperature range	-20°C ... +55°C
Storage temperature range	-20°C ... +85°C
Housing material	aluminum, anodized in black
Housing dimensions	LxWxH approx. 510 mm x 50 mm x 40 mm
Max. switching current	100 mA, short-circuit proof
Switching frequency	max. 60 kHz
Input DIGITAL (2x)	digital input IN0: to trigger the Scope function digital input IN1: to trigger the analog output value
Output DIGITAL (3x)	OUT0 ... OUT2: Qinv or Q, (adjustable via PC): Qinv: npn bright-switching (nnp n.c.) / pnp dark-switching (pnp n.o.) Q: pnp bright-switching (pnp n.c.) / npn dark-switching (nnp n.o.)
Output ANALOG (1x)	voltage output 0V...+10V or current output 4mA...20mA (can be switched under Windows®)
Tolerance range for digital outputs	parameterisable under Windows®
Transmitted light power	adjustable under Windows®
Averaging	over 32000 values (adjustable under Windows®)

Dimensions

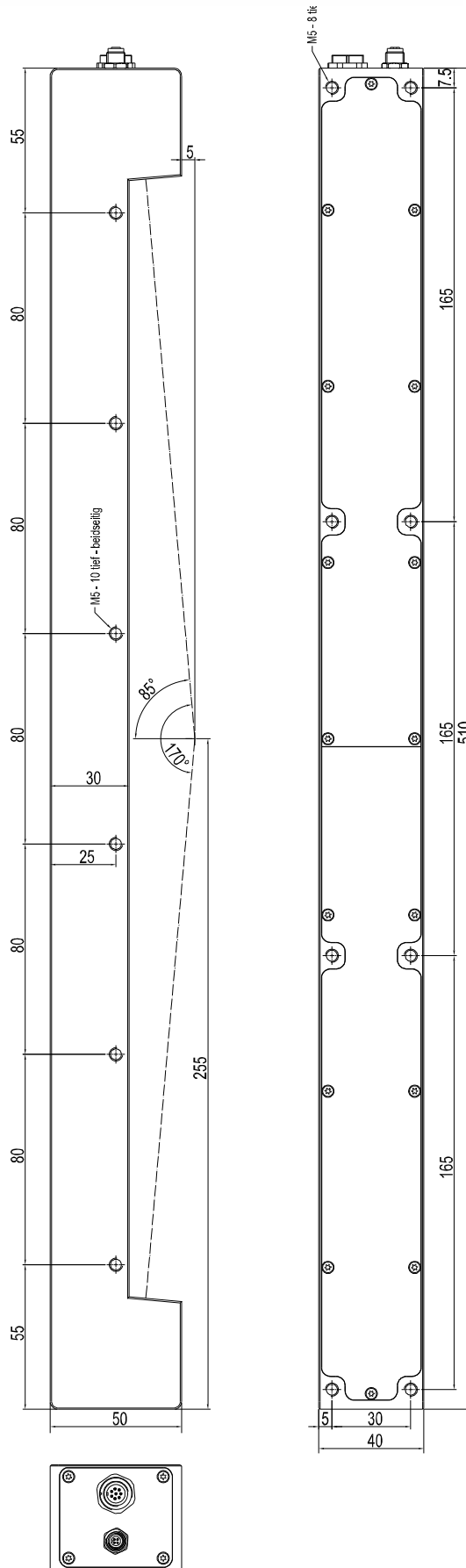

All dimensions in mm



Connector Assignment

Connection to PLC:

8-pole fem. connector Binder Series 712

Pin:	Color:	Assignment:
1	white	GND (0V)
2	brown	+24VDC ($\pm 10\%$)
3	green	IN0 (digital 0: 0 ... 1V, digital 1: +Ub - 10%)
4	yellow	IN1 (digital 0: 0 ... 1V, digital 1: +Ub - 10%)
5	grey	OUT0 (digital 0: Type 0 ... 1V, digital 1: Type +Ub - 10%)
6	pink	OUT1 (digital 0: Type 0 ... 1V, digital 1: Type +Ub - 10%)
7	blue	OUT2 (digital 0: Type 0 ... 1V, digital 1: Type +Ub - 10%)
8	red	ANALOG (0...+10V or 4 ... 20mA)

Connecting cable:
 cab-las8/SPS-(length)
 cab-las8/SPS-w-(length) (angle type, 90°)
 (standard length 2m)

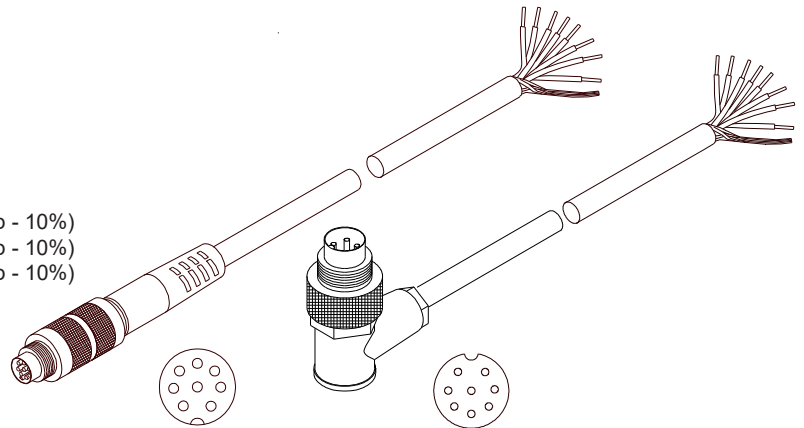

cab-las8/SPS-...
 (max. length 25m,
 outer jacket: PUR)

cab-las8/SPS-w-...
 (max. length 25m,
 outer jacket: PUR)

Connection to PC:

4-pol. fem. connector Binder Series 707

Pin:	Assignment:
1	+24VDC (+Ub, OUT)
2	GND (0V)
3	RxD
4	TxD

Connection via RS232 interface at the PC:

Connecting cable:
 cab-las4/PC-(length)
 cab-las4/PC-w-(length) (angle type 90°)
 (standard length 2m)

alternative:

Connection via USB interface at the PC:

Connecting cable (incl. driver software):
 cab-4/USB-(length)
 cab-4/USB-w-(length) (angle type 90°)
 (standard length 2m)

alternative:

Connection to local network via Ethernet bus:

Adapter:
 cab-4/ETH-500 (incl. software „SensorFinder“)
 (standard length 500mm)

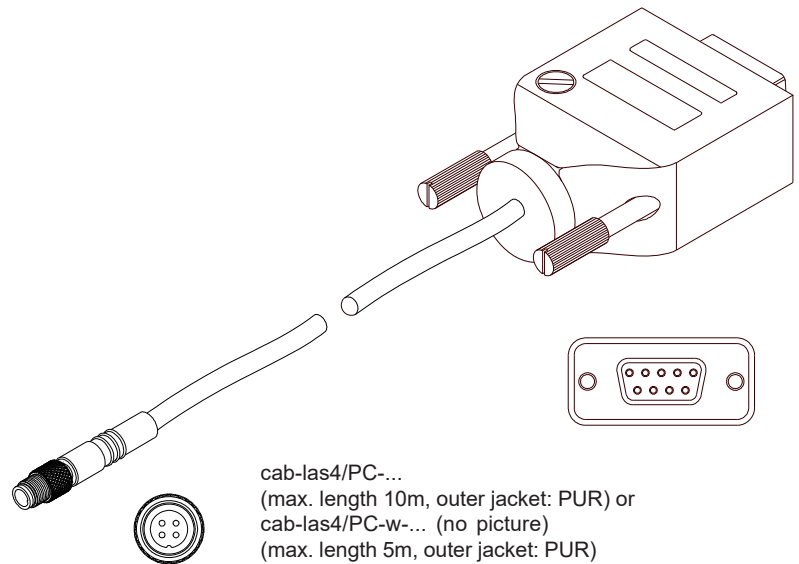

cab-las4/PC-...
 (max. length 10m, outer jacket: PUR) or
 cab-las4/PC-w-... (no picture)
 (max. length 5m, outer jacket: PUR)

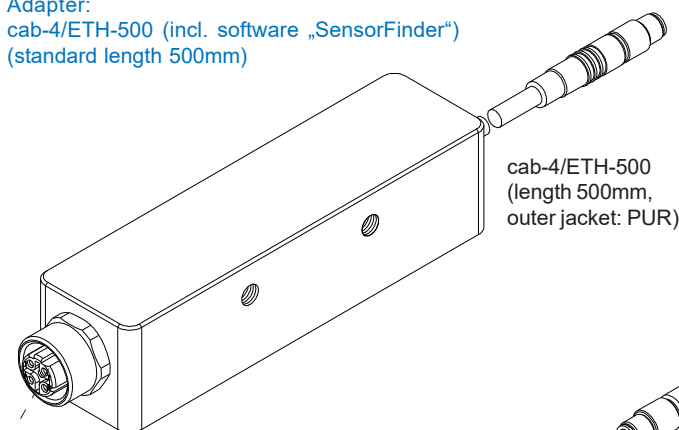

cab-4/ETH-500
 (length 500mm,
 outer jacket: PUR)

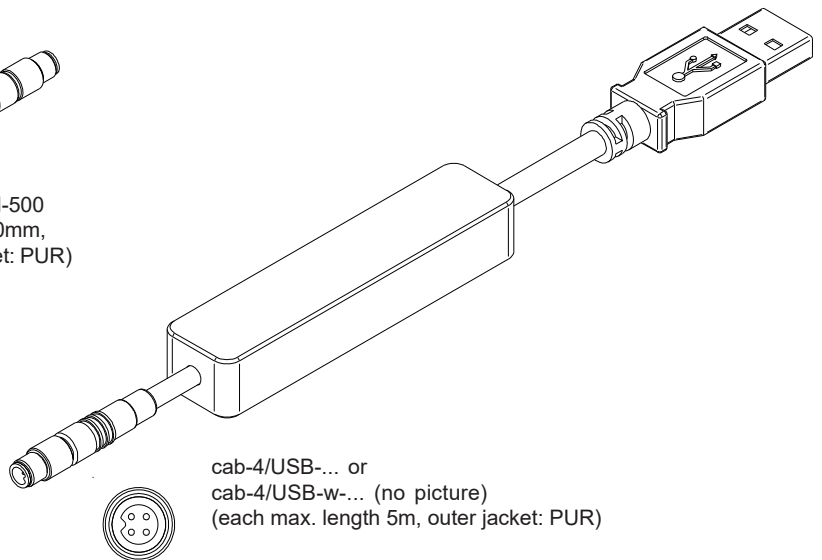

cab-4/USB-... or
 cab-4/USB-w-... (no picture)
 (each max. length 5m, outer jacket: PUR)

4-pole M12 fem. connector (D-coded) for
 connection of an external CAT5 cable, e.g.
 cab-eth/M12D-RJ45-flx-(length)
 (available in length 2m, 5m, 10m, or 20m)



Measuring Angles

For the gloss detection sensors of GLOSS Series different standard measuring angles are available:

- 20° for high-glossy surfaces (gloss degree >70 GU)
- 45° TAPPI standard (paper industry) for glossy surfaces
- 60° TAPPI standard (paper industry) for matt surfaces
- 75° for moderate glossy surfaces (gloss degree >10 GU and <70 GU)
- 85° for matt surfaces (gloss degree <10 GU)

[GU = Gloss Unit]



Measuring Principle

Measuring principle of the gloss detection sensor GLOSS-...:

A white-light LED projects a white light spot onto the surface to be inspected. A part of the light that is directly reflected from the measuring object is directed onto a receiver by the receiver optics (the receiver optics is arranged at the same angle from the vertical as the transmitter optics). Signal acquisition is performed with 12 bit.

The GLOSS sensor optionally can be "taught" up to 7 gloss levels or norm vectors. The gloss level or the detected norm vector is provided at the digital outputs. In addition the gloss level also is provided in analog form from 0 to 10V or from 4mA to 20mA.

A digital input allows external "teaching" of the sensor. An additional input allows the "freezing" of the analog output signal upon a positive input edge.

The GLOSS sensor allows highly flexible signal acquisition. The sensor, for example, can be operated in alternating-light mode (AC mode), which means the sensor is not influenced by external light, or in constant-light mode (DC mode), which provides outstanding high-speed sensor operation. An OFF function deactivates the sensor's integrated light source. With the stepless adjustment of the integrated light source, the selectable gain of the receiver signal, and an INTEGRAL function the sensor can be adjusted to almost any surface.

The sensor must be calibrated for gloss level detection. For this purpose a reference surface is required which by definition has a gloss level of 100GU (Gloss Units). Calibration then is performed with the PC software. The sensor also can be calibrated to foreign systems, which can be optionally activated in the PC software.

Parameters and measurement values can be exchanged between PC and sensor either through RS232 or Ethernet (using an Ethernet adaptor). Through the interface all the parameters can be stored in the non-volatile EEPROM of the sensor.

The PC software facilitates the parameterisation, diagnostics, and adjustment of the sensor system (oscilloscope function). The software furthermore provides a data recorder function that automatically records data and stores them on the hard disk of the PC.

GLOSS sensors are temperature-compensated over a range of 0°C to 80°C.

Possible firmware updates can be easily performed through the RS232 interface, even with the sensor system in installed condition.

When parameterisation is finished, the color sensor continues to operate with the current parameters in STAND-ALONE mode without a PC.

Parameterization

Windows® user interface:

(The current software version is available for download on our website.)

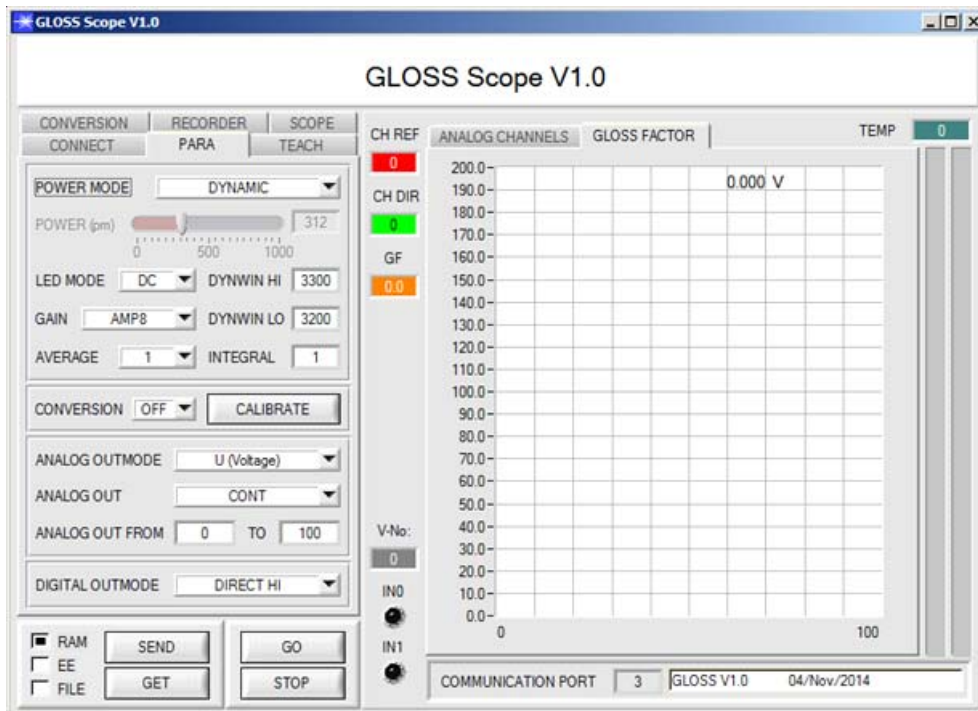

The gloss sensor is parameterized under Windows® with the GLOSS-Scope software. The Windows® user interface facilitates the teach-in process at the sensor and supports the operator in the task of adjustment and commissioning of the sensor.

The software provides various display elements and a graphic window for the visualisation of all the data that are important for parameterisation.

In the CONVERSION tab a certain conversion value can be assigned to the gloss factor GF signal.

The GLOSS-Scope software features a data recorder (RECORDER tab).

The SCOPE tab visualizes an oscilloscope.

Firmware Update

Firmware update by means of the software „FirmwareLoader“:

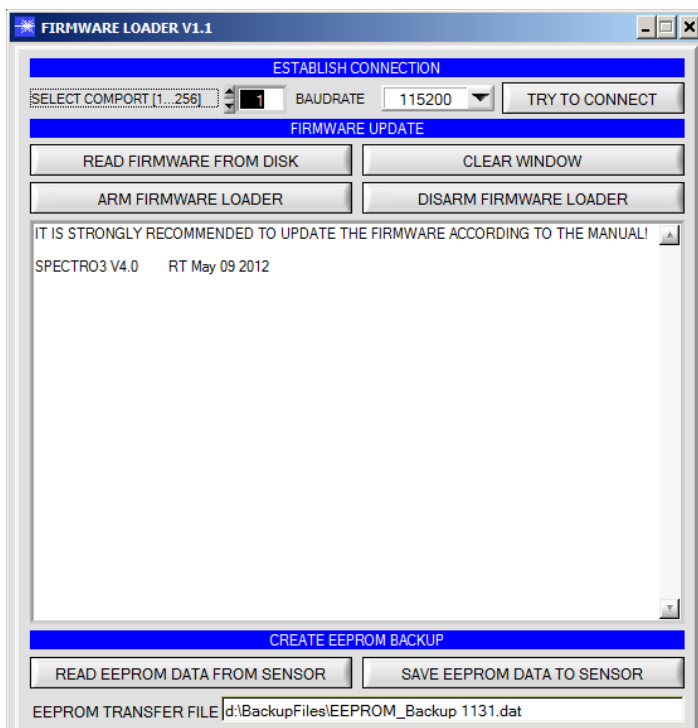

The software „Firmware Loader“ allows the user to perform an automatic firmware update. The update will be carried out through the RS232 interface.

An initialisation file (xxx.ini) and a firmware file (xxx.elf.S) are required for performing a firmware update. These files can be obtained from your supplier. In some cases an additional firmware file for the program memory (xxx.elf.p.S) is also needed, and this file will be automatically provided together with the other two files.



Calibration Unit



GLOSS-5-85°-CAL
(Calibration unit, optional)

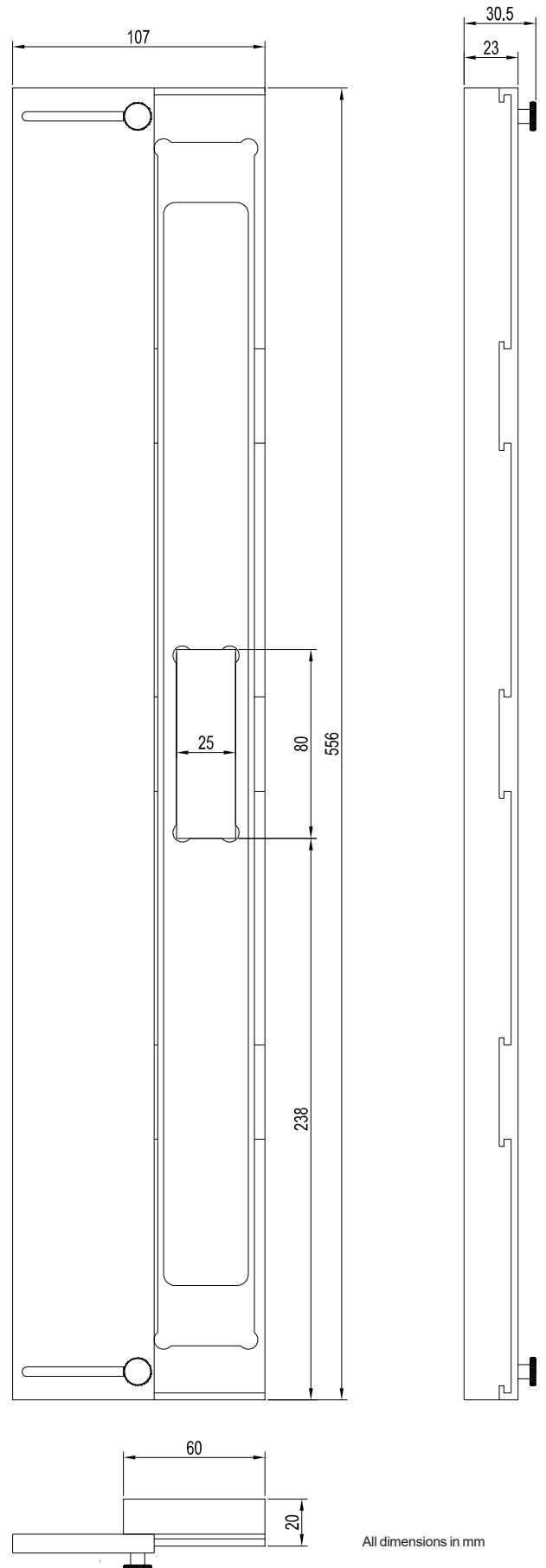

All dimensions in mm



Offline Unit

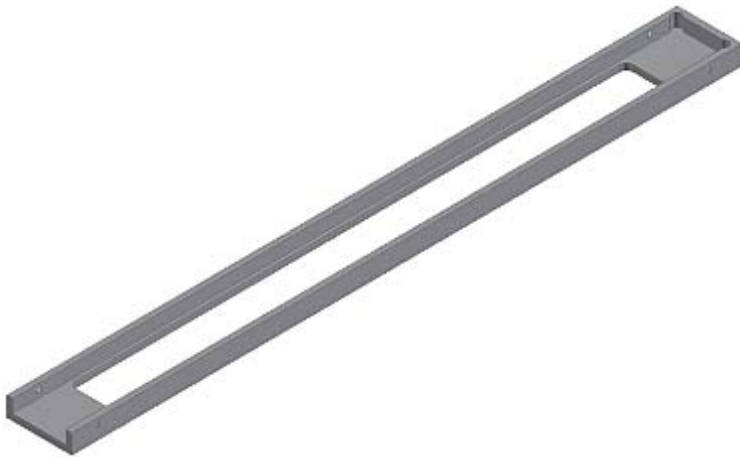

GLOSS-5-85°-OFL
(Offline unit / spacer, optional)

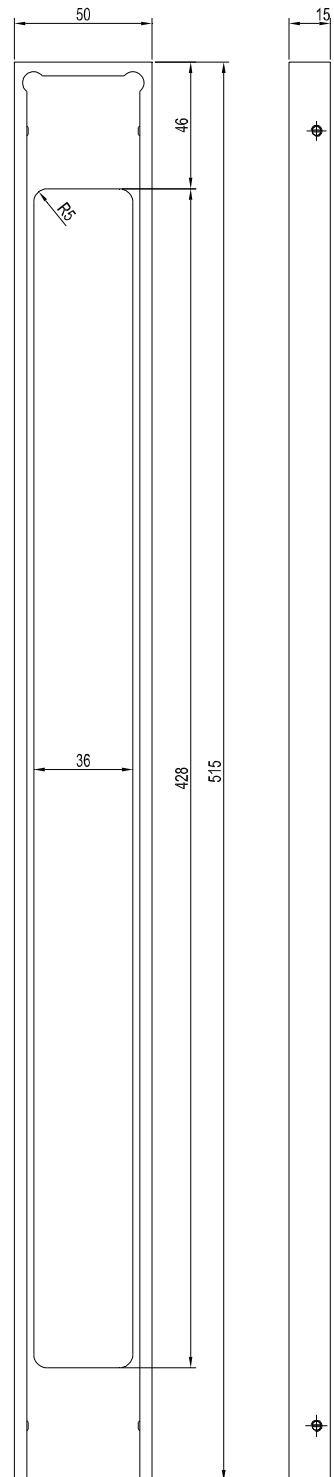

All dimensions in mm