

L-LAS Series

▶ L-LAS-TB-F-6x1-20/40-AL

- Line laser <math><0.4\text{ mW}</math>, wave length 670 nm, laser class 1
- Visible laser line, typ. 6 mm x 1 mm
- Measuring range typ. 5.6 mm
- Resolution up to 2 μm (depends on selected scan frequency)
- Transmitter/receiver distance 20 mm
- Integrated interference filter
- CCD line detector with 512 pixel, 4096 subpixel (8-fold)
- RS232 interface (USB or Ethernet converter available)
- 1 digital input, 2 digital outputs
- 1 analog output (0 ... +10V)
- Max. scan frequency selectable via software (2 kHz or 4 kHz)
- Compact aluminum housing, anodized in black
- Scratch-resistant optics cover made of glass

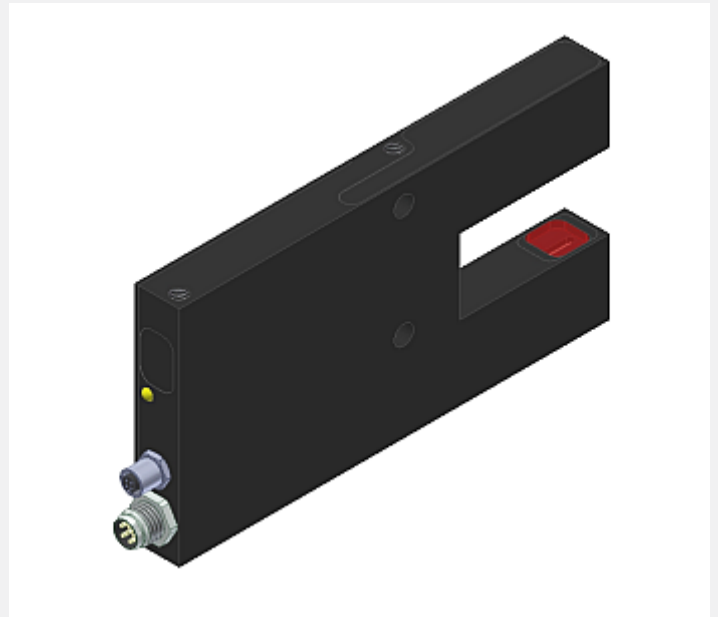

Design

Product name:

L-LAS-TB-F-6x1-20/40-AL
 (incl. Windows® PC software
 L-LAS-TB-Scope as from V5.0)

Mounting holes
 (threaded M5)

Position of laser line (AxB):
6x1 (A=6mm, B=1mm)

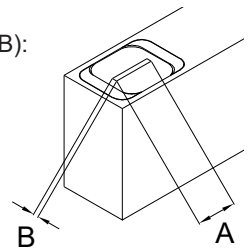

Receiver optics
 (scratch-resistant
 optics cover made
 of glass)

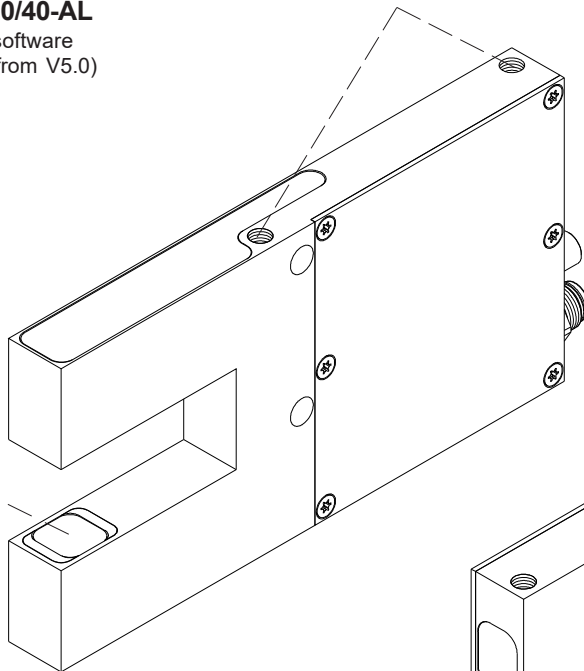

LED yellow
 (POWER-LED,
 multifunctional)

4-pole fem. connector
 Binder Series 707
 (RS232)

6-pole connector
 Binder Series 718
 (PLC)

Connecting cable:
 cab-las4/PC or
 cab-4/USB or
 cab-4/ETH

Connecting cable:
 cab-las6/SPS-fem

Mounting holes

Sturdy aluminum
 housing, anodized
 in black





Technical Data

Model	L-LAS-TB-F-6x1-20/40-AL
Laser	Semiconductor laser, 670 nm, DC operation, < 0.4 mW max. opt. power, laser class 1 acc. to DIN EN 60825-1. The use of these laser sensors therefore requires no additional protective measures.
Working distance	Transmitter/receiver distance: 20 mm (= fork width)
Measuring range	typ. 5.6 mm
Resolution	typ. 2 µm (Normal Speed mode), typ. 4 µm (Fast Speed mode)
Reproducibility	typ. ± 2 µm (Normal Speed mode), typ. ± 4 µm (Fast Speed mode)
Linearity	typ. 0.2% of FSR (full scale range)
Optical filter	Interference filter
Analog output (1x) (ANA)	1x analog voltage output: 0 ... +10V
Digital outputs (2x) (OUT0, OUT1)	OUT0: (-) Measuring value < lower tolerance threshold OUT1: (+) Measuring value > upper tolerance threshold pnp bright-switching/npn dark-switching or pnp dark-switching/npn bright-switching, adjustable under Windows®, 100 mA, short-circuit proof
Digital input (1x) (IN0)	IN0: External input (multifunctional) input voltage +Ub/0V, with protective circuit
Voltage supply	+24VDC (± 10%)
Sensitivity setting	adjustable under Windows® via PC
Laser power correction	adjustable under Windows® via PC
Current consumption	typ. 150 mA
Enclosure rating	electronics: IP54, optics: IP67
Operating temperature range	-10°C ... +50°C
Storage temperature range	-20°C ... +85°C
Housing material	aluminum, anodized in black
Housing dimensions	LxWxH approx. 115 mm x 60 mm x 12 mm (without flange connectors)
Type of connector	6-pole circular connector type Binder Series 718 (PLC/Power) 4-pole female circular connector type Binder Series 707 (PC/RS232)
LED indication	yellow LED: Power-LED (multifunctional)
EMC test acc. to	DIN EN 60947-5-2
Scan frequency	Normal Speed mode (high resolution): max. 2 kHz Fast Speed mode (half resolution): max. 4 kHz can be switched under Windows®
Max. switching current	100 mA, short-circuit proof
Interface	RS232, parameterisable under Windows®
Connecting cable	Connection to PC: cab-las4/PC or cab-4/USB or cab-4/ETH Connection to PLC: cab-las6/SPS-fem
Output polarity	bright/dark switching, can be switched under Windows®



Connector Assignment

**Connection to PLC:
6-pole connector Binder Series 718**

Pin:	Color:	Assignment:
1	brown	+24VDC ($\pm 10\%$)
2	white	GND (0V)
3	blue	IN0
4	black	OUT0 (-)
5	grey	OUT1 (+)
6	pink	ANA (voltage 0 ... +10V)

Connecting cable:
cab-las6/SPS-fem-(length)
(Standard length 2m)



cab-las6/SPS-fem-...
(max. length 5m, outer jacket: PUR)

**Connection to PC:
4-pole fem. connector Binder Series 707**

Pin:	Assignment:
1	+24VDC (+Ub, OUT)
2	GND (0V)
3	RxD
4	TxD

Connection via RS232 interface at the PC:

Connecting cable:
cab-las4/PC-(length)
cab-las4/PC-w-(length) (angle type 90°)
(standard length 2m)

alternative:

Connection via USB interface at the PC:

USB converter (incl. driver software):
cab-4/USB-(length)
cab-4/USB-w-(length) (angle type 90°)
(standard length 2m)

alternative:

Connection to local network via Ethernet bus:

Ethernet converter (incl. software „SensorFinder“):
cab-4/ETH-500
(standard length 0.5m)

Optional: External CAT5 cable, e.g.
cab-eth/M12D-RJ45-flx-(length)

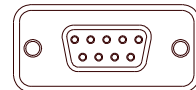
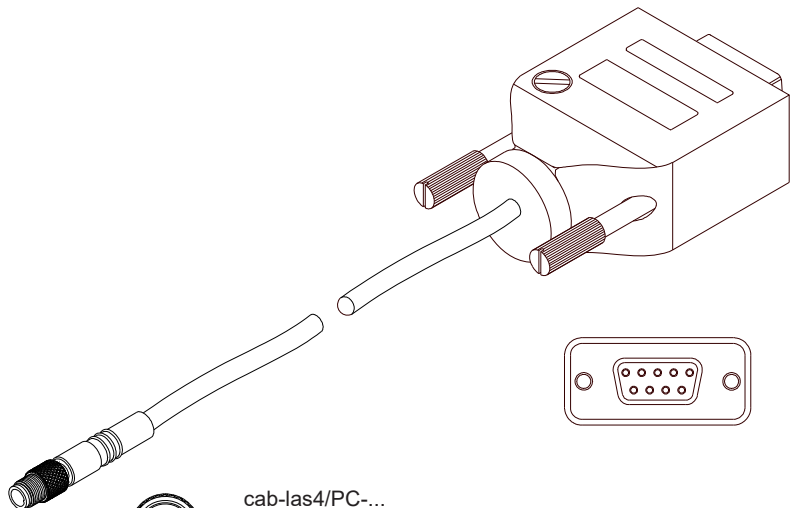

cab-las4/PC-...
(max. length 10m, outer jacket: PUR) or
cab-las4/PC-w-... (no picture)
(max. length 5m, outer jacket: PUR)

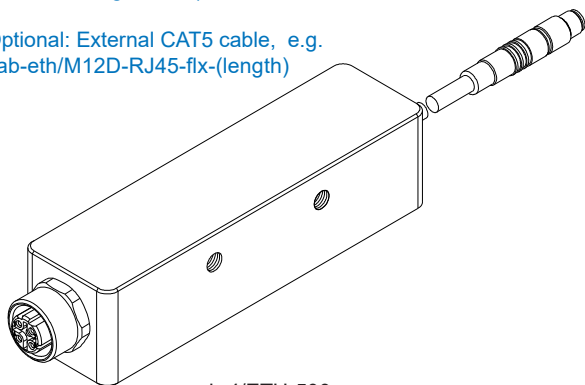

cab-4/ETH-500
(length 0.5m, outer jacket: PUR)
4-pole M12 fem. conn. (D-coded)
for connection of an external
CAT5 cable, e.g.
cab-eth/M12D-RJ45-flx-(length)

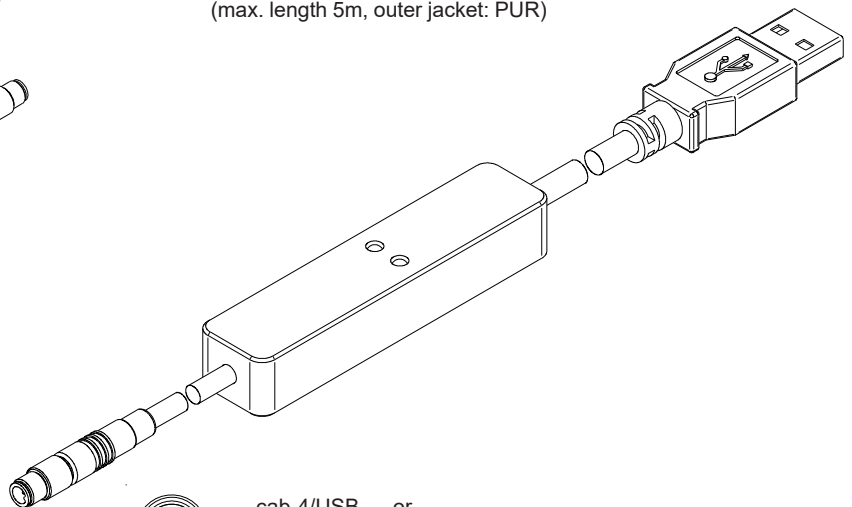

cab-4/USB-... or
cab-4/USB-w-... (no picture)
(each max. length 5m, outer jacket: PUR)

Parameterization
Windows® user interface:

(The current software version is available for download on our website.)

The L-LAS-TB-...-AL sensor can be easily parameterised with the Windows® user interface L-LAS-TB-Scope (as of V5.0). For this purpose the sensor is connected to the PC with the serial interface cable cab-las4/PC (or cab-4/USB or cab-4/ETH). When parameterisation is finished, the PC can be disconnected again.

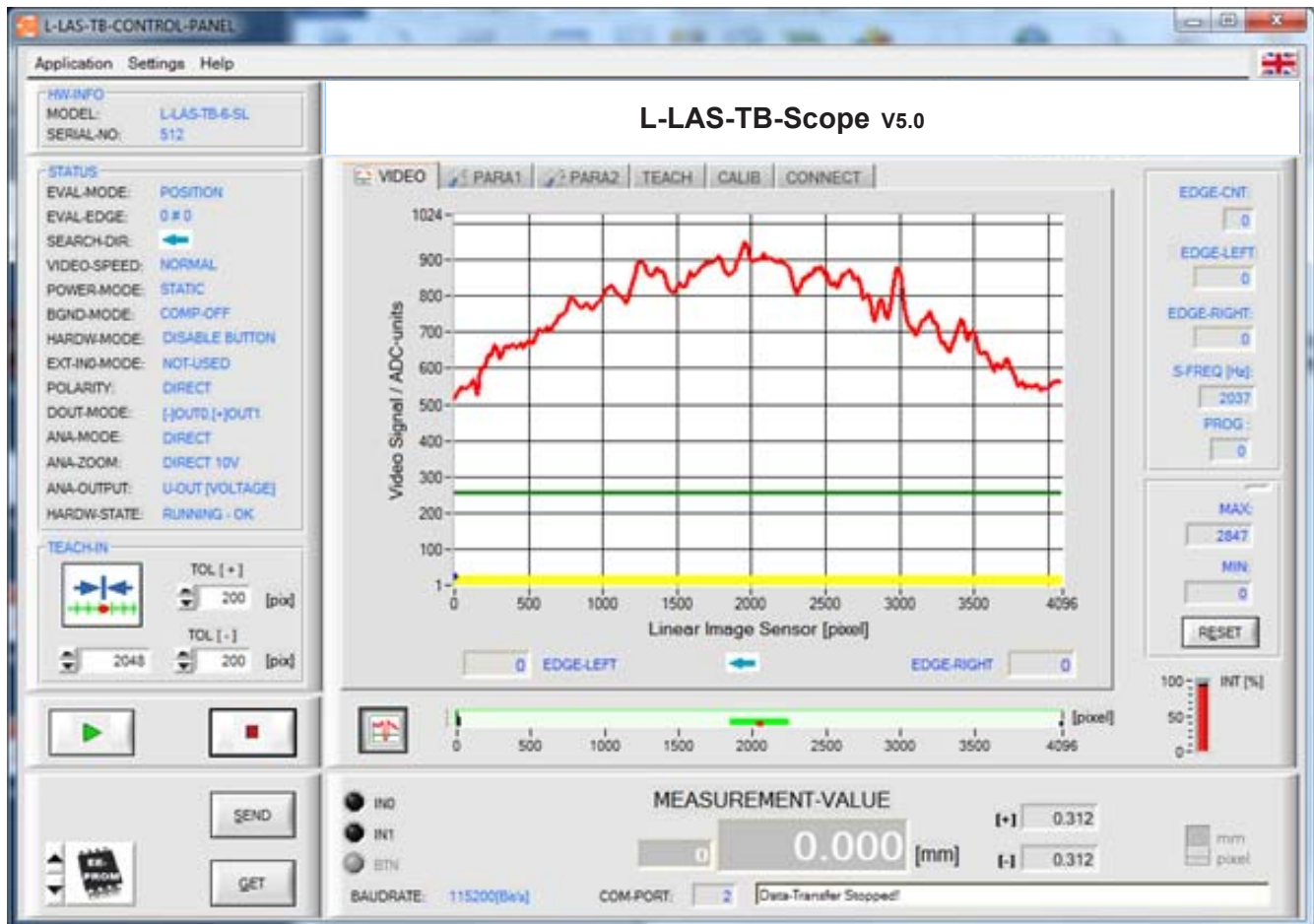
Windows® user interface:

With the help of the L-LAS-TB-Scope software the following settings can be made at the sensor:

- Setting of laser power and type of automatic power correction
- Polarity of digital outputs
- Different evaluation modes
- Start of the teach process by software button
- Setting of tolerance ranges for monitoring the measured value
- Selection of scan frequency

Furthermore, various numerical and graphical measured quantities can be visualized with the L-LAS-TB-Scope software. For example, the raw data of the CCD line sensor can be displayed graphically and numerically.